

NIVEL 1

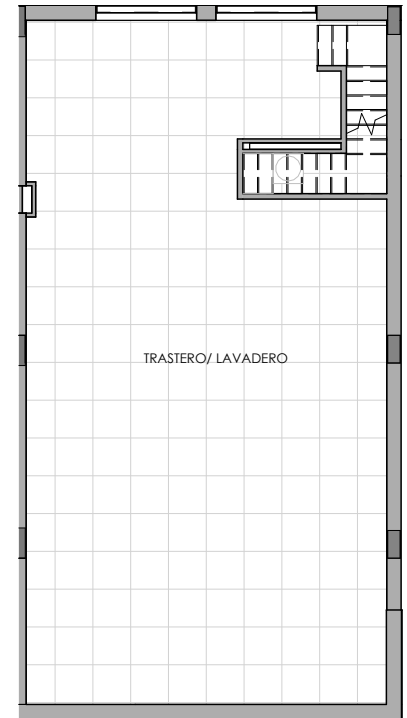

NIVEL 0

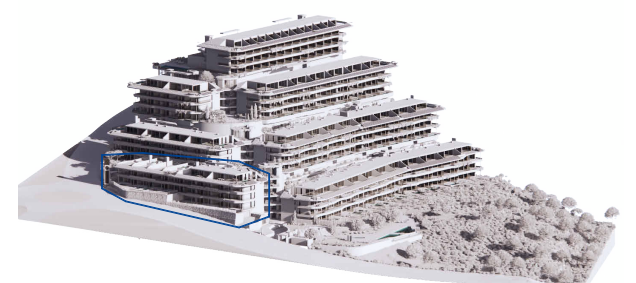
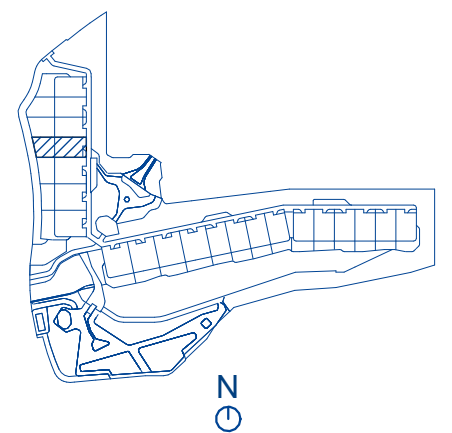

VIRGINIA (Módulo D1)  
Garden Villa D  
Apartamento nº 166

SUPERFICIE CONSTRUIDA VIVIENDA.....	196.37 m <sup>2</sup>
SUPERFICIE CONSTRUIDA TERRAZA.....	22.72 m <sup>2</sup>
SUPERFICIE JARDÍN.....	41.12 m <sup>2</sup>
SUPERFICIE LÁMINA & PLAYA PISCINA.....	17.85 m <sup>2</sup>
<b>SUPERFICIE EXTERIOR TOTAL</b>	<b>81.69 m<sup>2</sup></b>

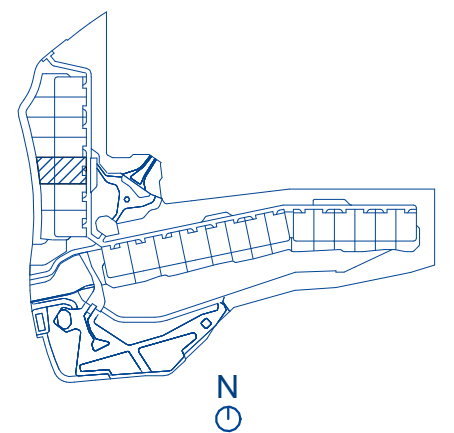
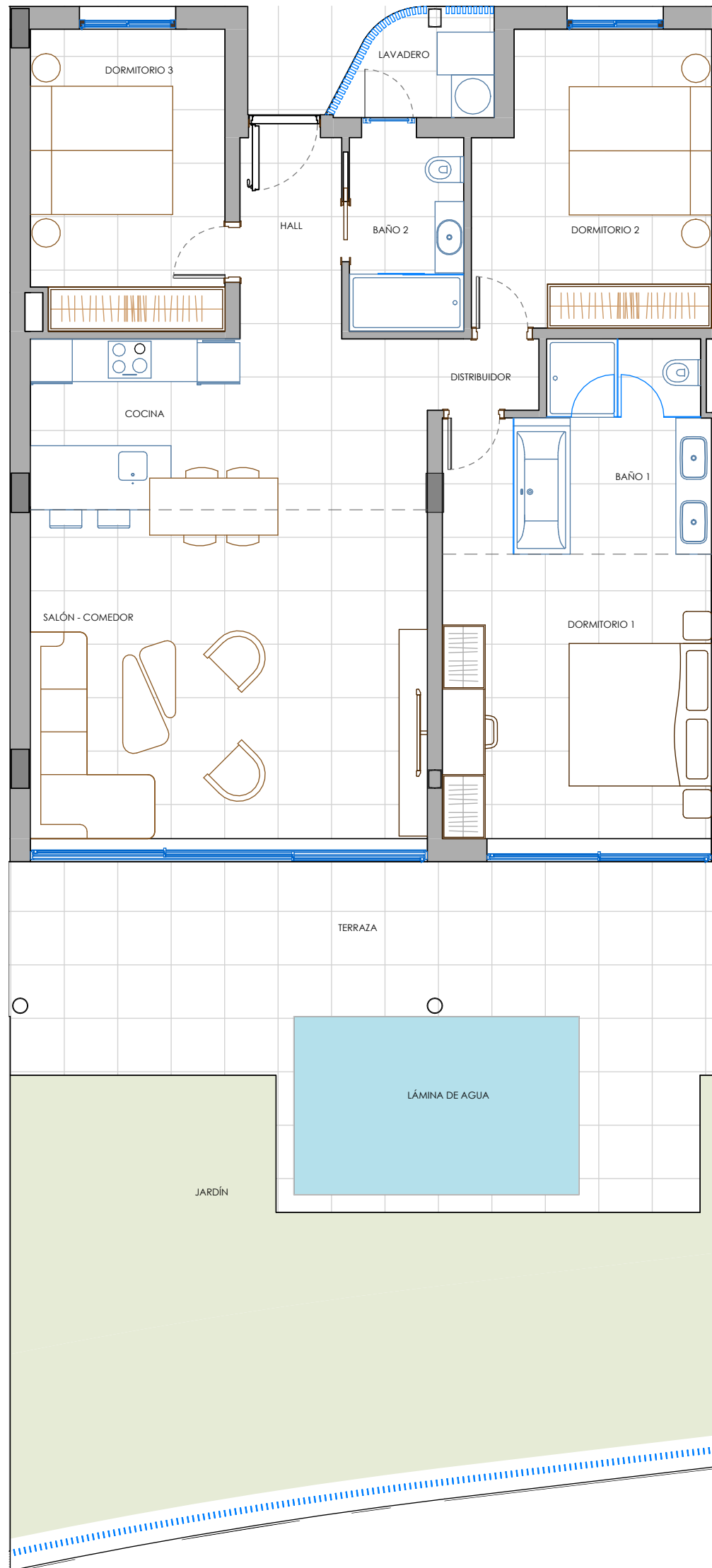

VIRGINIA (Módulo D1)  
Garden Villa E  
Apartamento nº 167

SUPERFICIE CONSTRUIDA VIVIENDA.....	117.82 m <sup>2</sup>
SUPERFICIE CONSTRUIDA TERRAZA.....	31.48 m <sup>2</sup>
SUPERFICIE JARDÍN.....	50.24 m <sup>2</sup>
SUPERFICIE LÁMINA DE AGUA.....	10.00 m <sup>2</sup>
<b>SUPERFICIE EXTERIOR TOTAL</b>	<b>91.72 m<sup>2</sup></b>

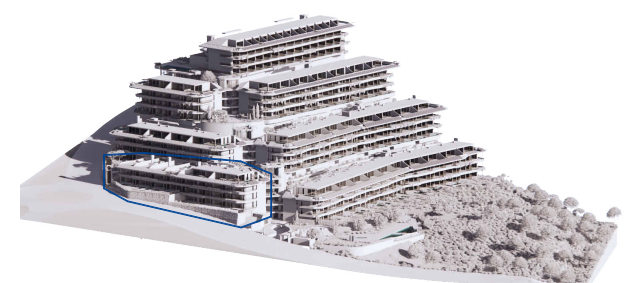



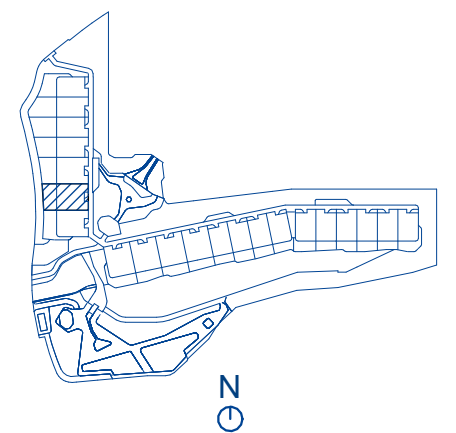
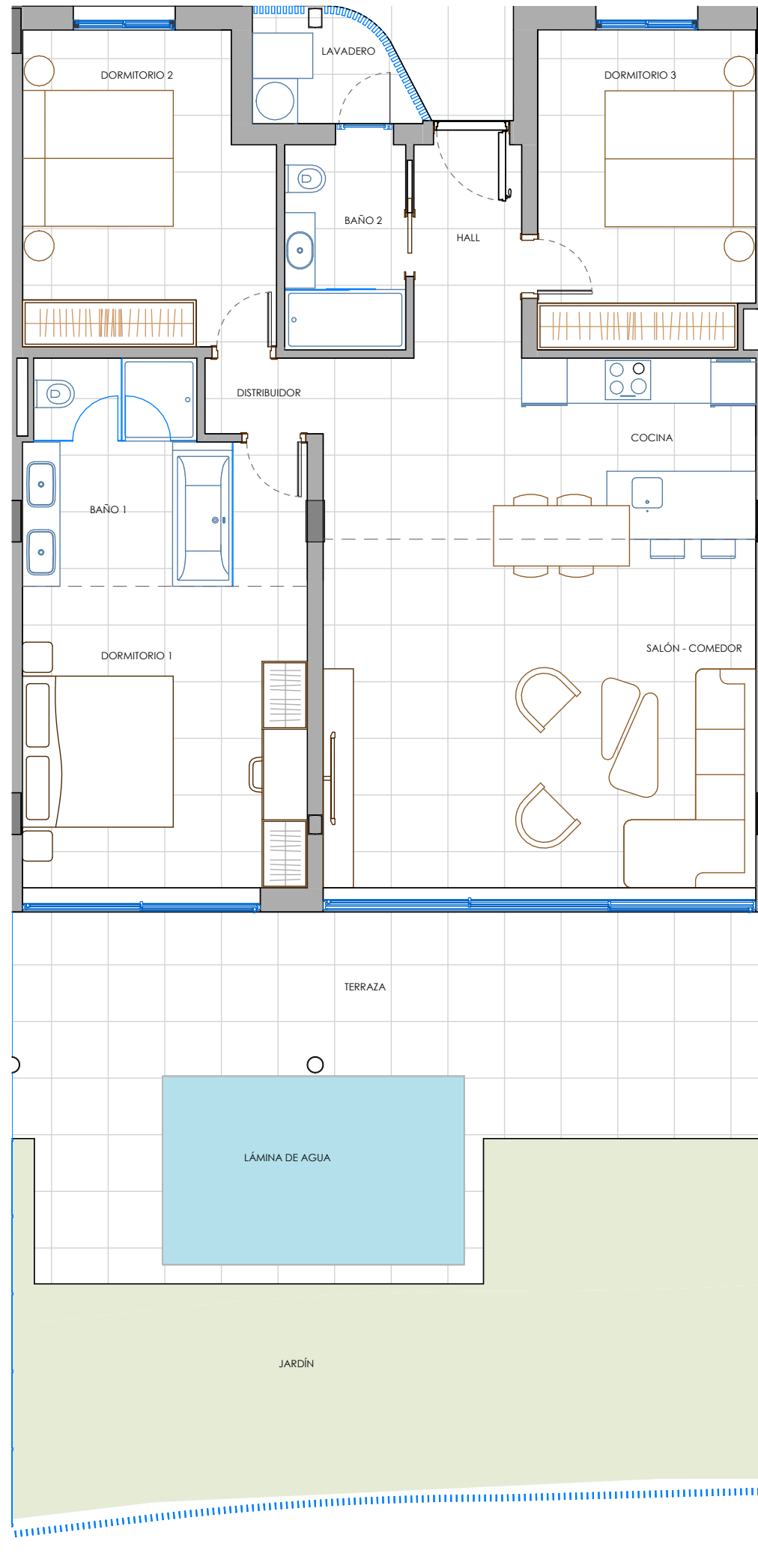

VIRGINIA (Módulo D1)  
Garden Villa F  
Apartamento nº 168

SUPERFICIE CONSTRUIDA VIVIENDA.....	117.68 m <sup>2</sup>
SUPERFICIE CONSTRUIDA TERRAZA.....	31.44 m <sup>2</sup>
SUPERFICIE JARDÍN.....	39.77 m <sup>2</sup>
SUPERFICIE LÁMINA DE AGUA.....	10.00 m <sup>2</sup>
<b>SUPERFICIE EXTERIOR TOTAL</b>	<b>81.21 m<sup>2</sup></b>

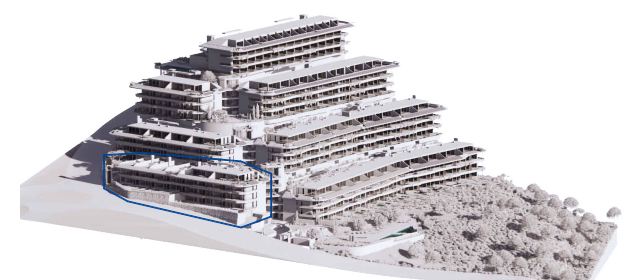

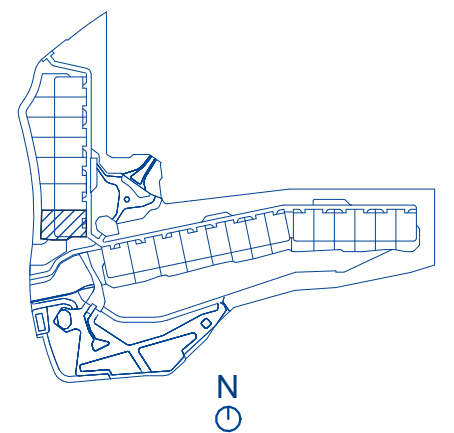
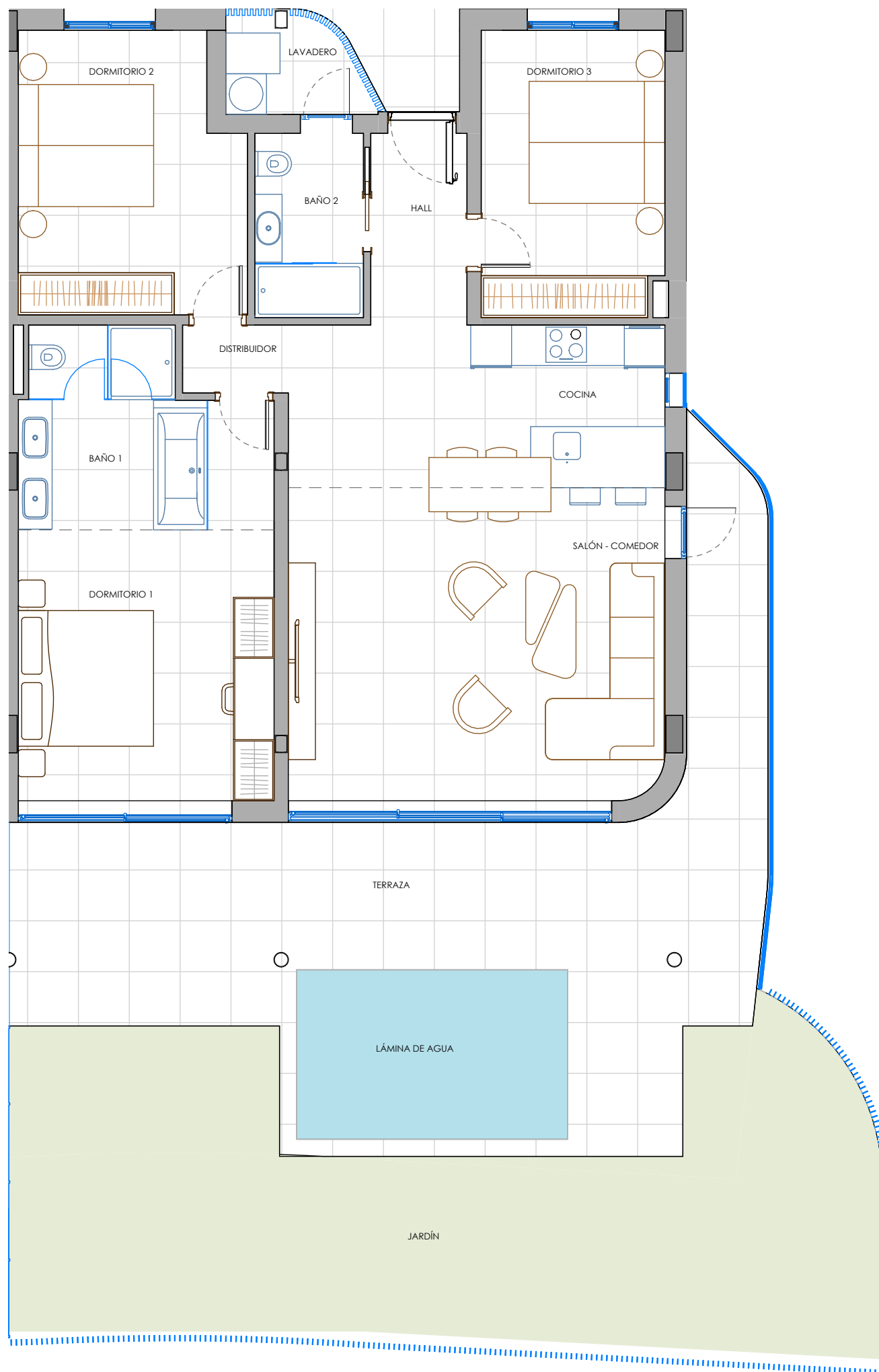

**VIRGINIA (Módulo D1)**  
**Garden Villa G**  
**Apartamento nº 169**

SUPERFICIE CONSTRUIDA VIVIENDA.....	117.47 m <sup>2</sup>
SUPERFICIE CONSTRUIDA TERRAZA.....	41.54 m <sup>2</sup>
SUPERFICIE JARDÍN.....	53.23 m <sup>2</sup>
SUPERFICIE LÁMINA DE AGUA.....	10.00 m <sup>2</sup>
<b>SUPERFICIE EXTERIOR TOTAL</b>	<b>104.77 m<sup>2</sup></b>

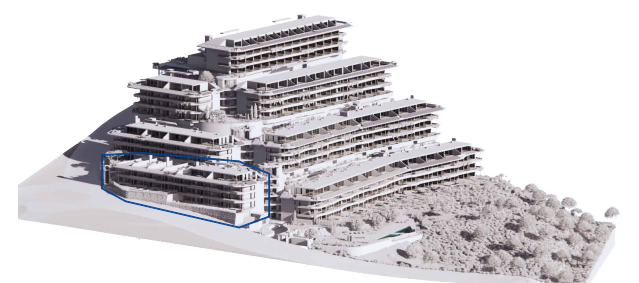

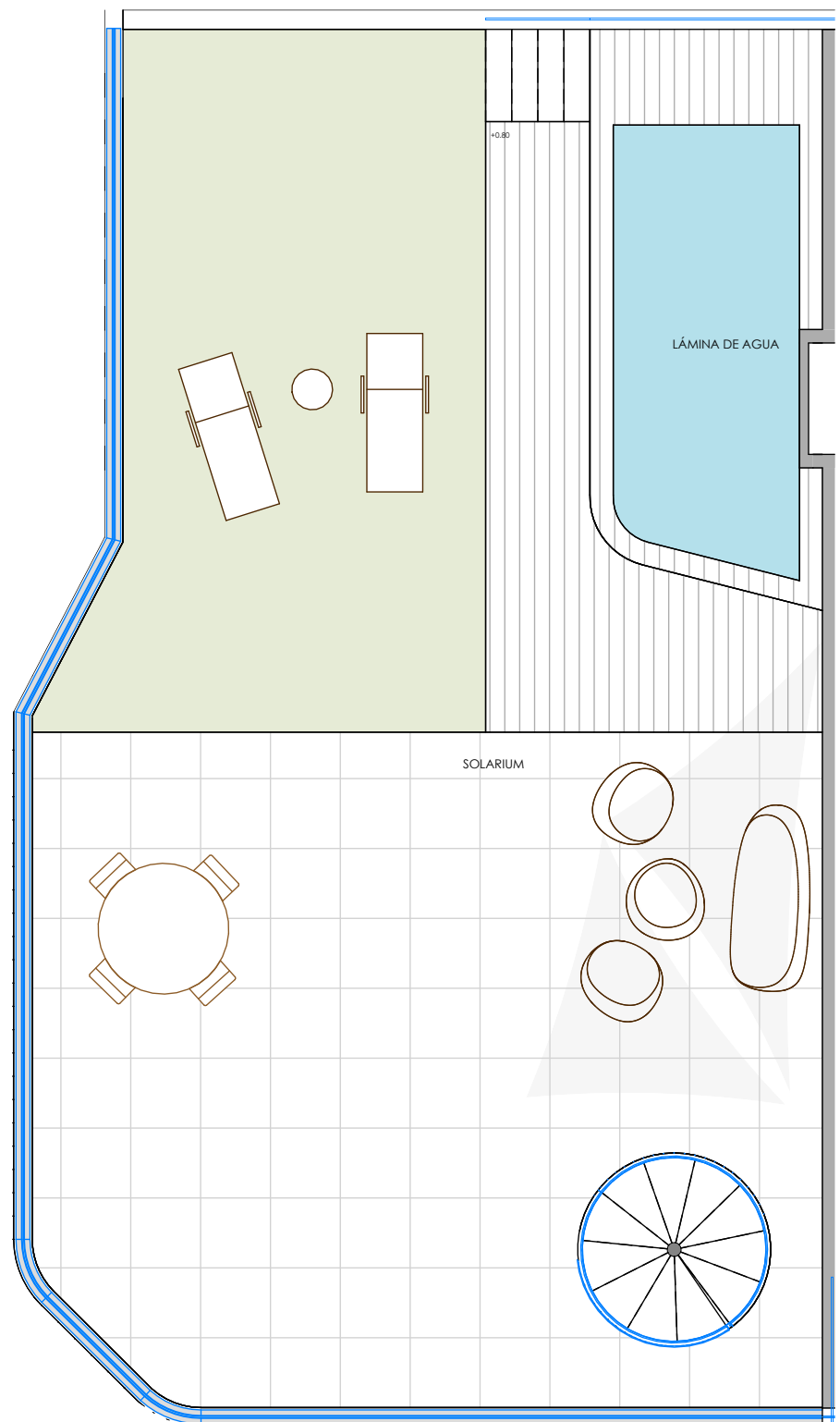
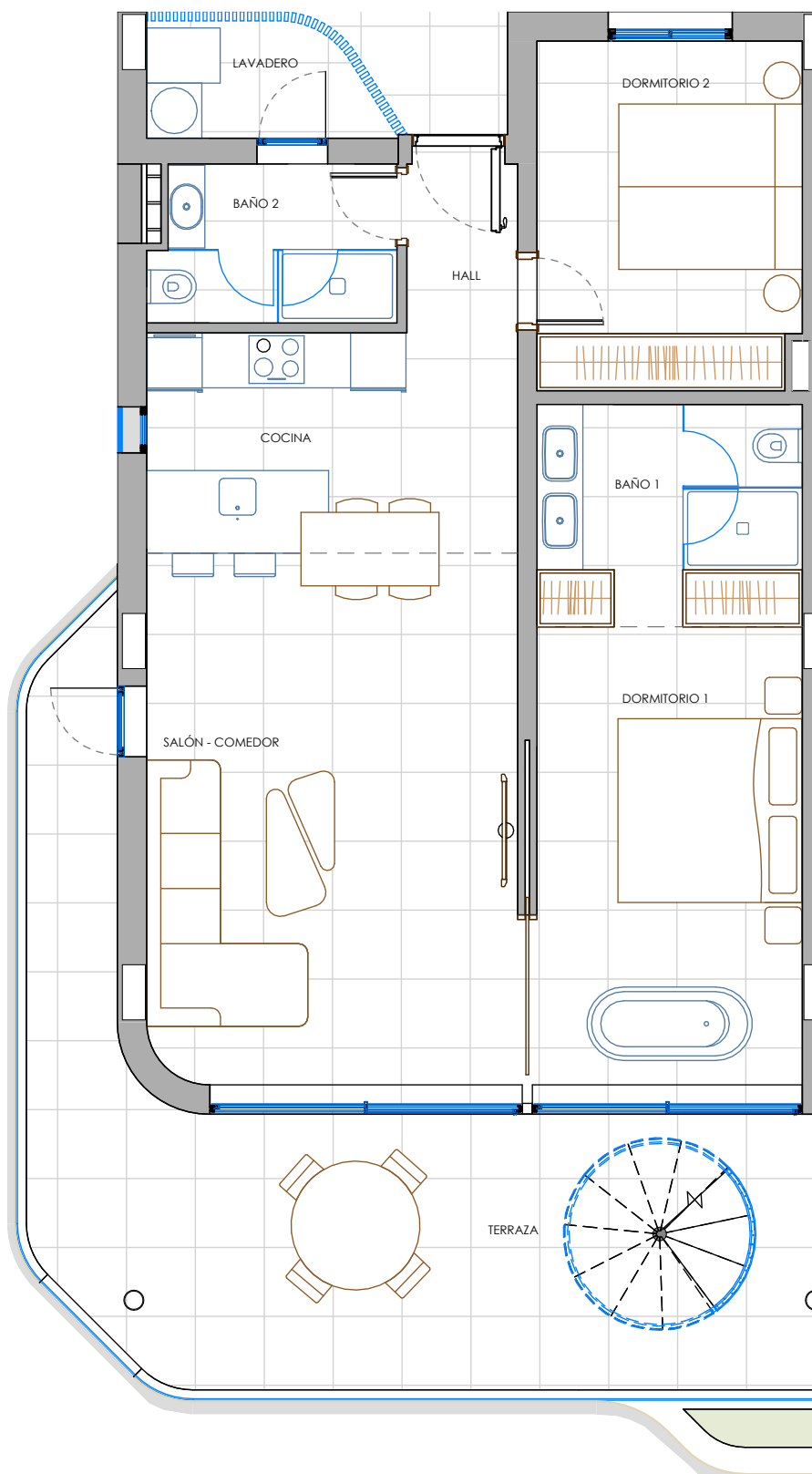

VIRGINIA (Módulo D1)  
ÁTICO SOLARIUM A  
Apartamento nº 170

SUPERFICIE CONSTRUIDA VIVIENDA.....	88.90 m <sup>2</sup>
SUPERFICIE CONSTRUIDA TERRAZA.....	35.41 m <sup>2</sup>
SUPERFICIE LÁMINA DE AGUA & SOLARIUM....	161.24 m <sup>2</sup>
<b>SUPERFICIE EXTERIOR TOTAL</b>	<b>196.65 m<sup>2</sup></b>

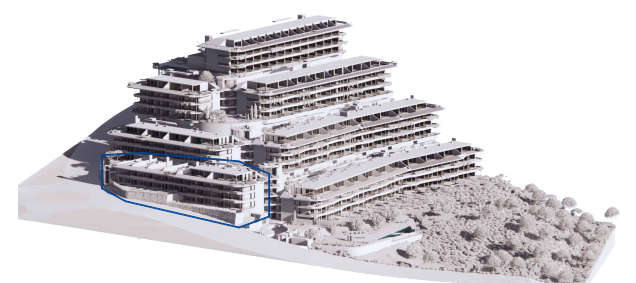
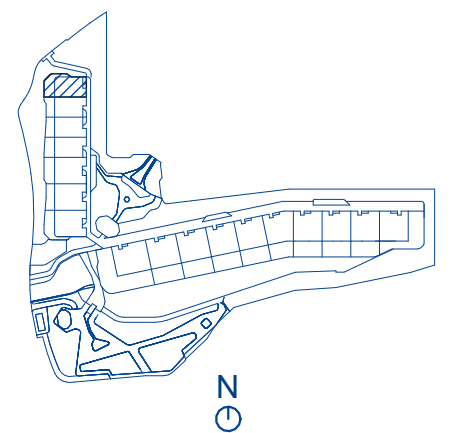

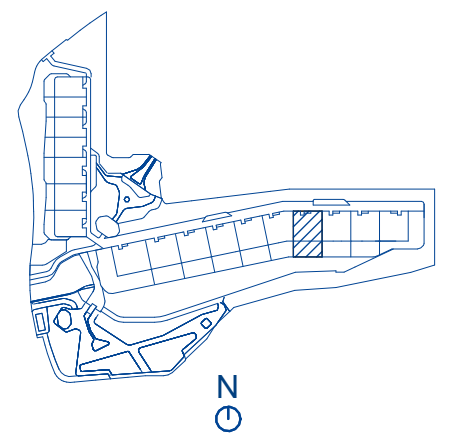
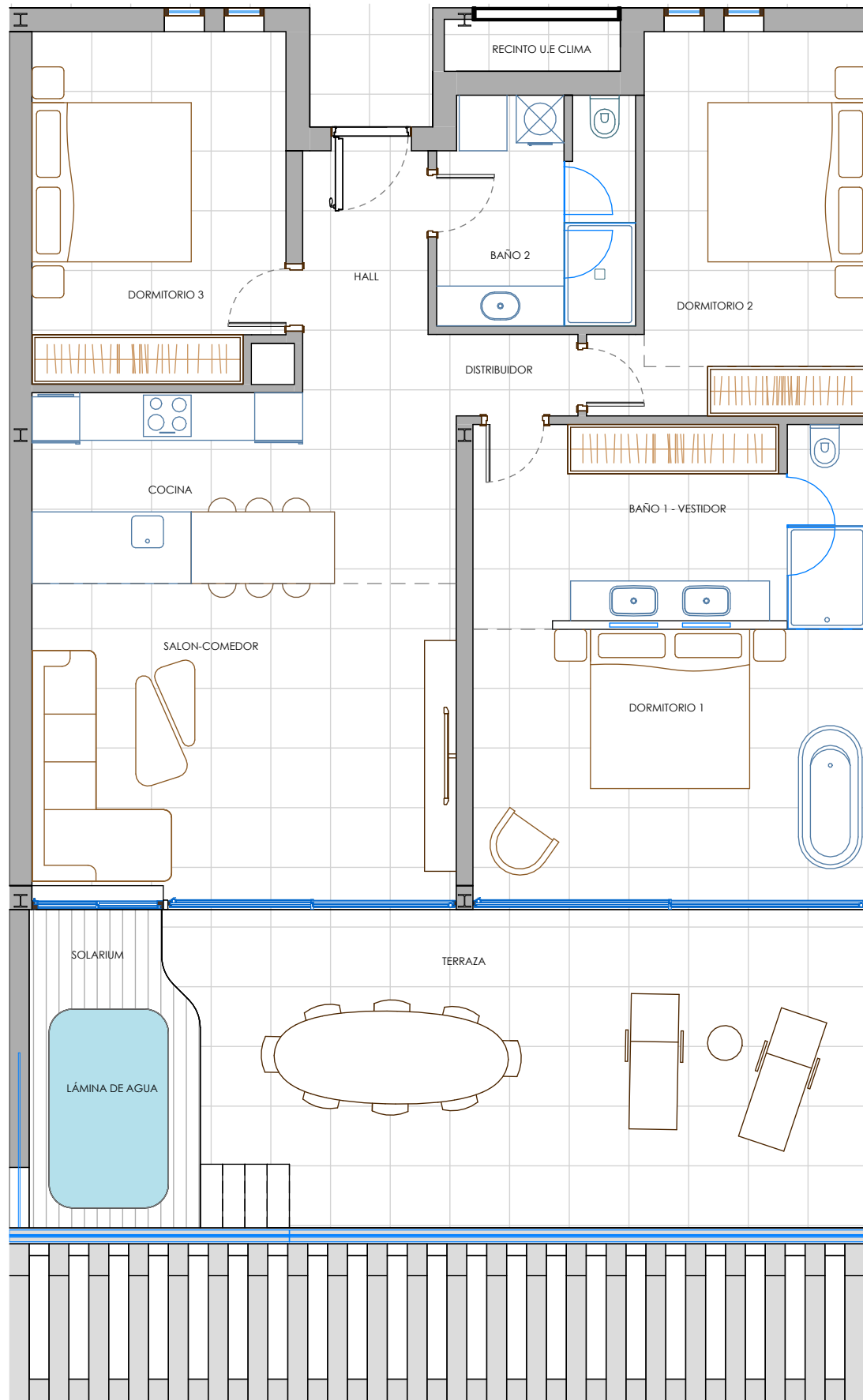

NIÁGARA (Módulo D2)  
Ático G  
Apartamento nº 230

SUPERFICIE CONSTRUIDA VIVIENDA.....121.52 m<sup>2</sup>  
 SUPERFICIE CONSTRUIDA TERRAZA.....45.90 m<sup>2</sup>  
 SUPERFICIE LÁMINA DE AGUA & SOLARIUM....8.10 m<sup>2</sup>  
**SUPERFICIE EXTERIOR TOTAL 37.80 m<sup>2</sup>**

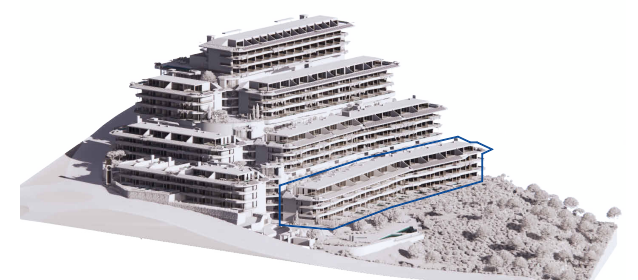

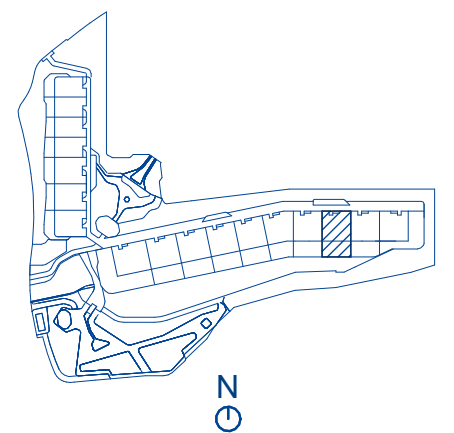
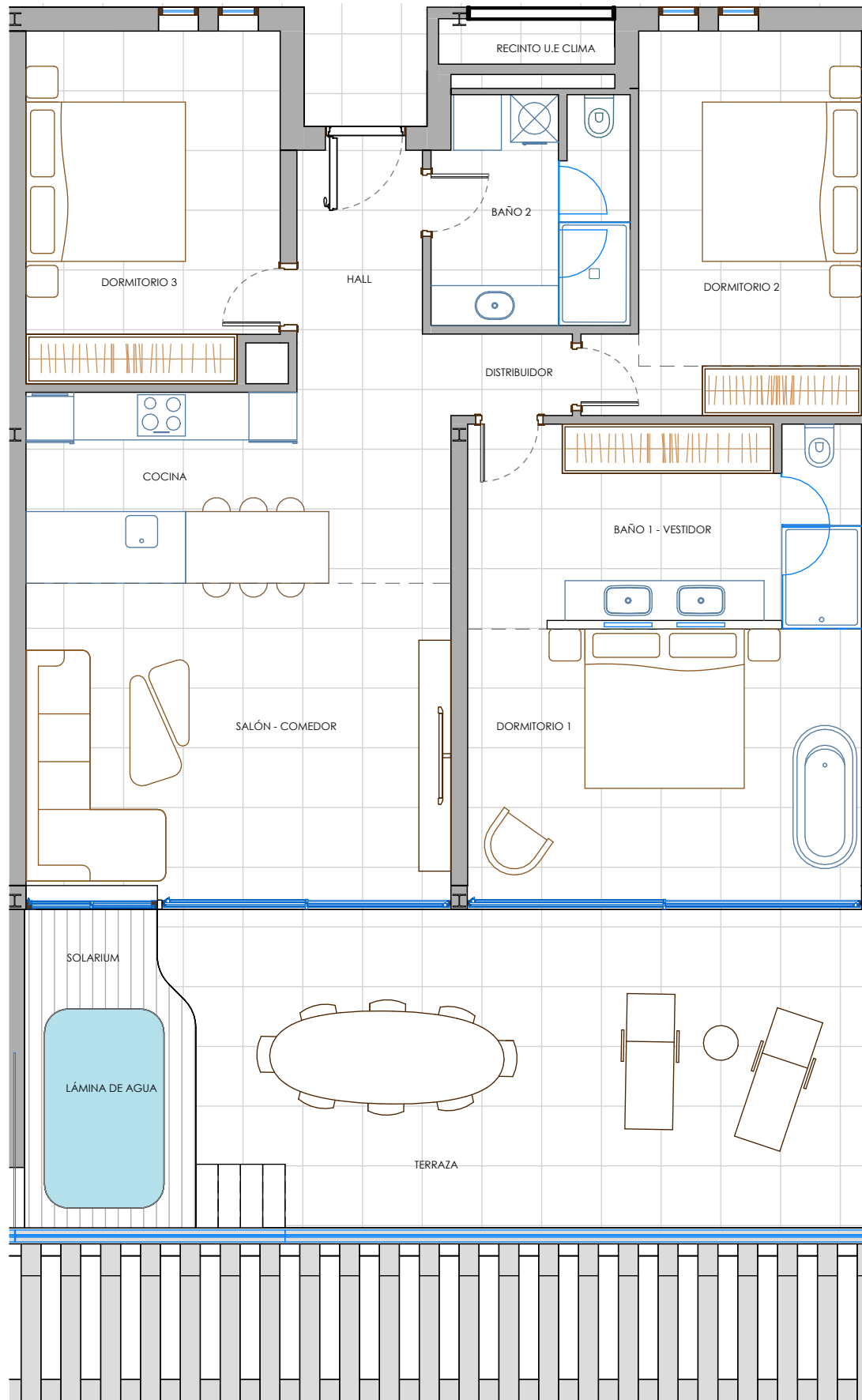

NIÁGARA (Módulo D2)  
Ático H  
Apartamento nº 231

SUPERFICIE CONSTRUIDA VIVIENDA.....119.79 m<sup>2</sup>  
 SUPERFICIE CONSTRUIDA TERRAZA.....37.16 m<sup>2</sup>  
 SUPERFICIE LÁMINA DE AGUA & SOLARIUM....8.10 m<sup>2</sup>  
**SUPERFICIE EXTERIOR TOTAL 45.26 m<sup>2</sup>**

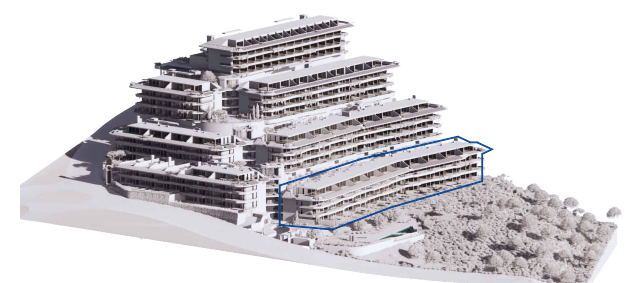

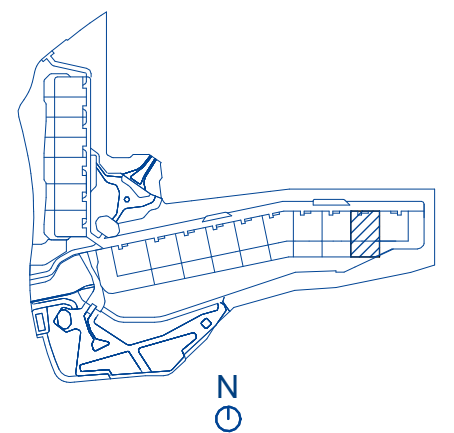
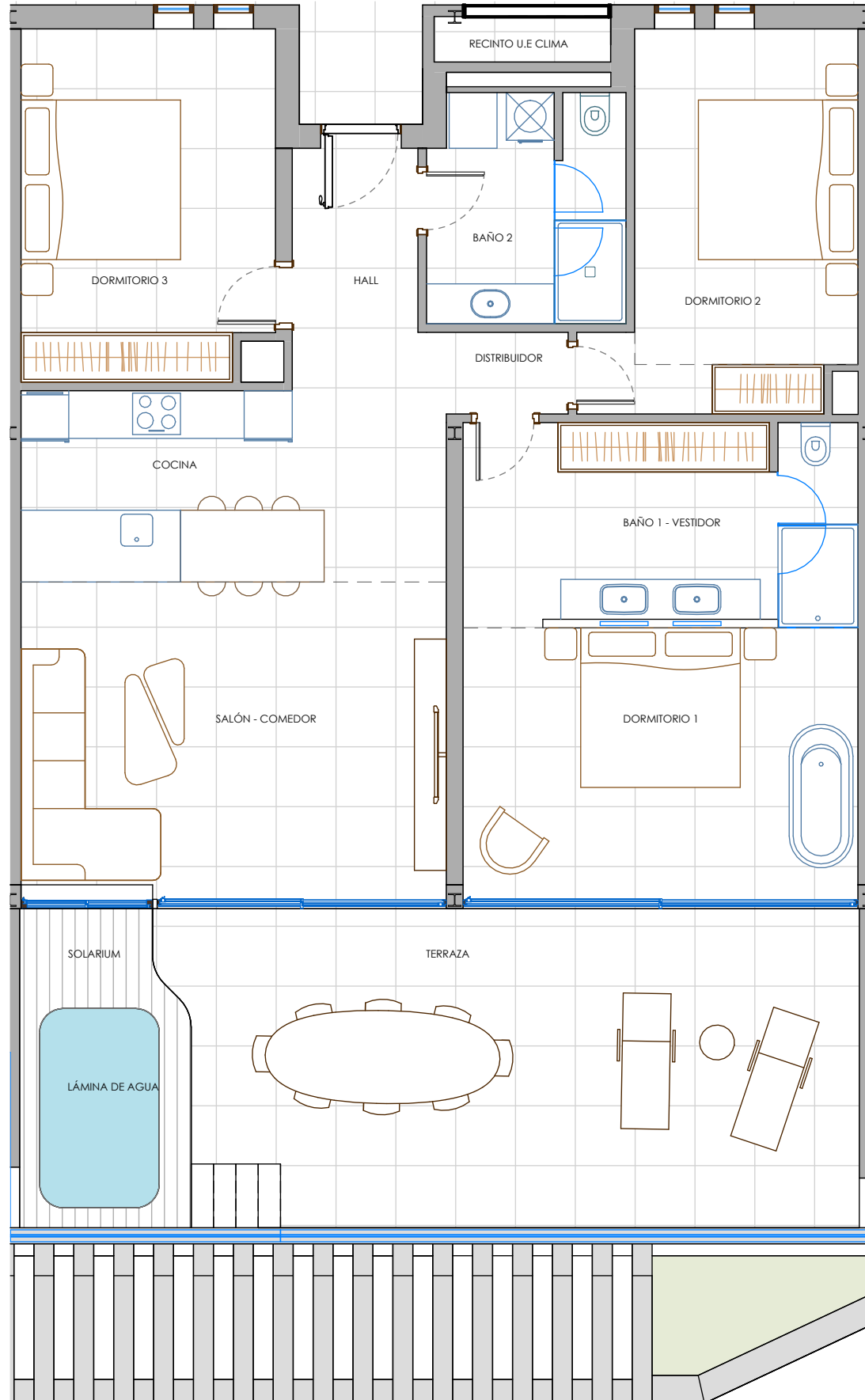

NIÁGARA (Módulo D2)  
Ático I  
Apartamento nº 232

SUPERFICIE CONSTRUIDA VIVIENDA.....119.79 m<sup>2</sup>  
 SUPERFICIE CONSTRUIDA TERRAZA.....37.16 m<sup>2</sup>  
 SUPERFICIE LÁMINA DE AGUA & SOLARIUM....8.10 m<sup>2</sup>  
**SUPERFICIE EXTERIOR TOTAL 45.26 m<sup>2</sup>**

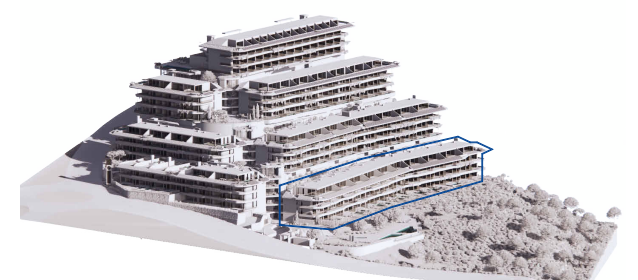

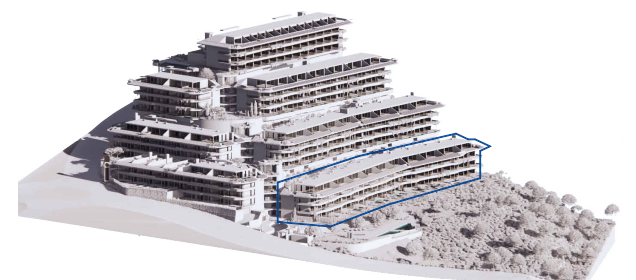
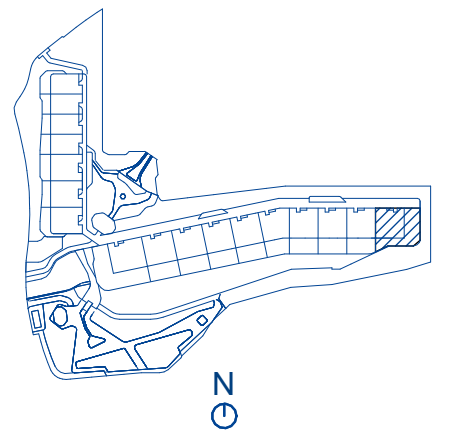
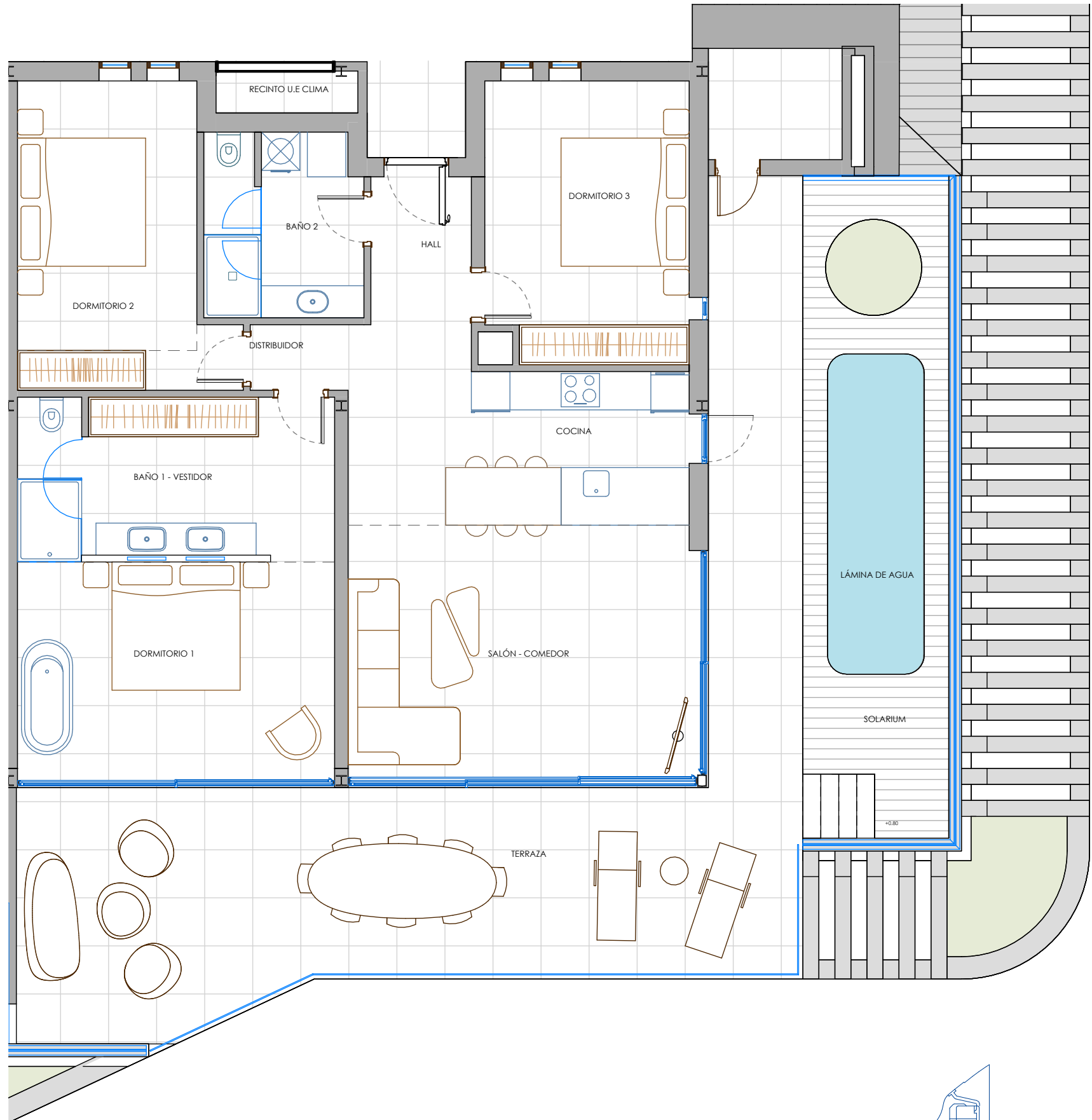

NIÁGARA (Módulo D2)  
Ático J  
Apartamento nº 233

SUPERFICIE CONSTRUIDA VIVIENDA.....127.76 m<sup>2</sup>  
 SUPERFICIE CONSTRUIDA TERRAZA.....59.16 m<sup>2</sup>  
 SUPERFICIE LÁMINA DE AGUA & SOLARIUM....22.29 m<sup>2</sup>  
**SUPERFICIE EXTERIOR TOTAL 81.45 m<sup>2</sup>**



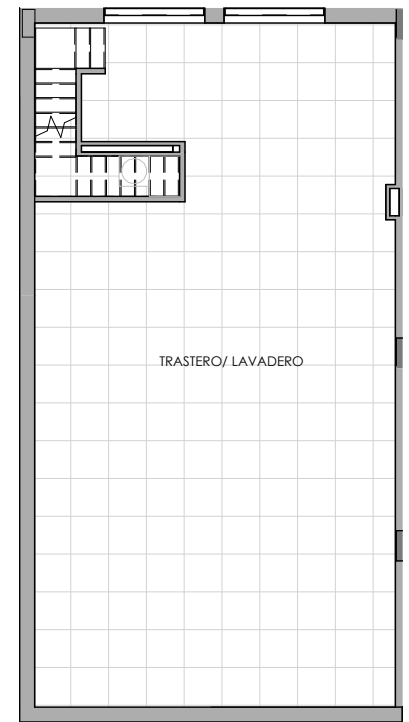
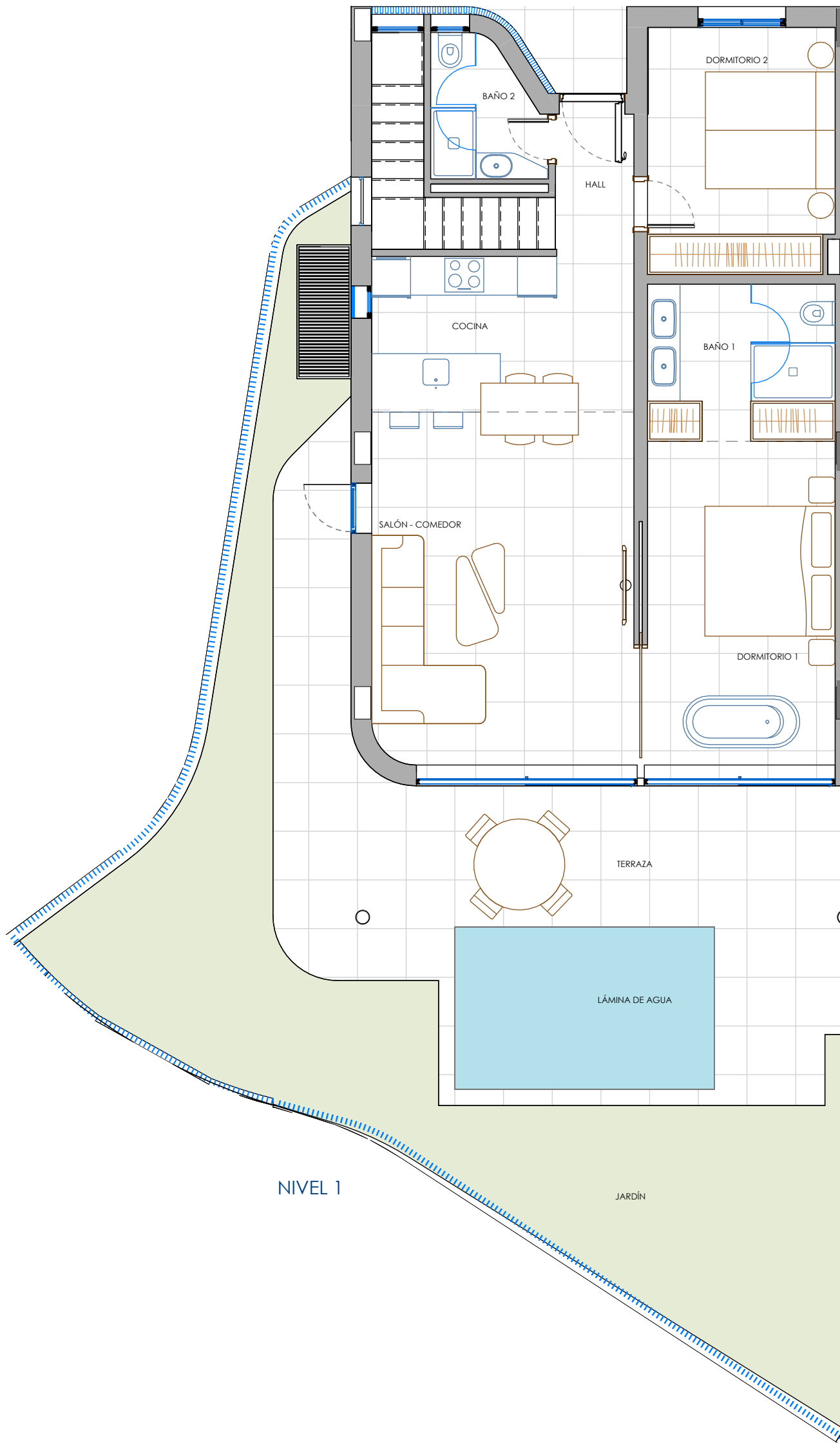

NIVEL 0

NIVEL 1

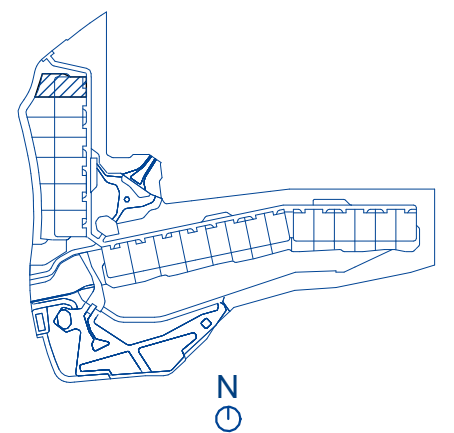

VIRGINIA (Módulo D1)  
Garden Villa A  
Apartamento nº 163

SUPERFICIE CONSTRUIDA VIVIENDA.....	196.62 m <sup>2</sup>
SUPERFICIE CONSTRUIDA TERRAZA.....	34.48 m <sup>2</sup>
SUPERFICIE JARDÍN.....	51.17 m <sup>2</sup>
SUPERFICIE LÁMINA DE AGUA.....	10.00 m <sup>2</sup>
<b>SUPERFICIE EXTERIOR TOTAL</b>	<b>95.65 m<sup>2</sup></b>

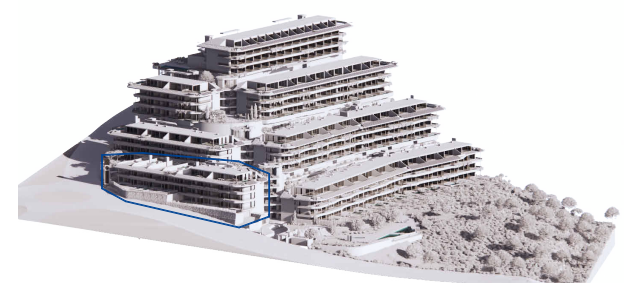

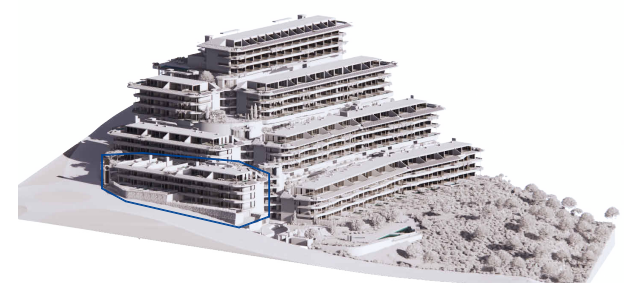
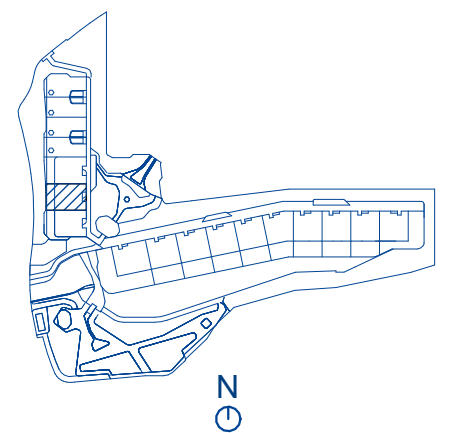
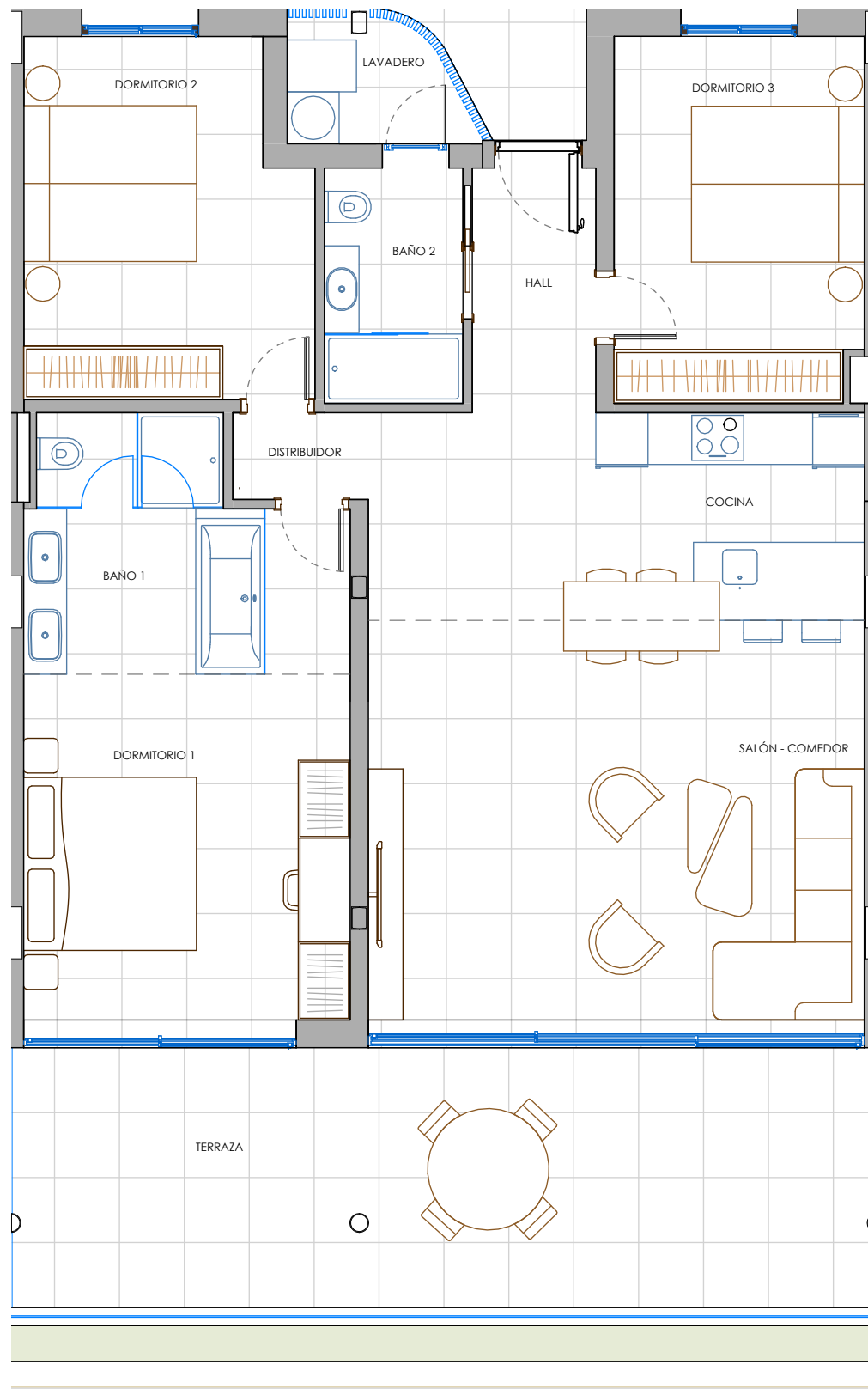

VIRGINIA (Módulo D1)  
P2 F  
Apartamento nº 178

SUPERFICIE CONSTRUIDA VIVIENDA..... 117.65 m<sup>2</sup>  
SUPERFICIE CONSTRUIDA TERRAZA..... 32.10 m<sup>2</sup>

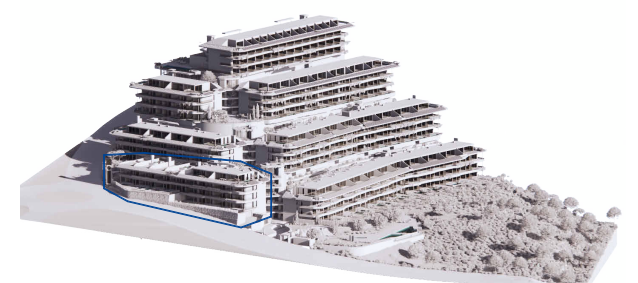
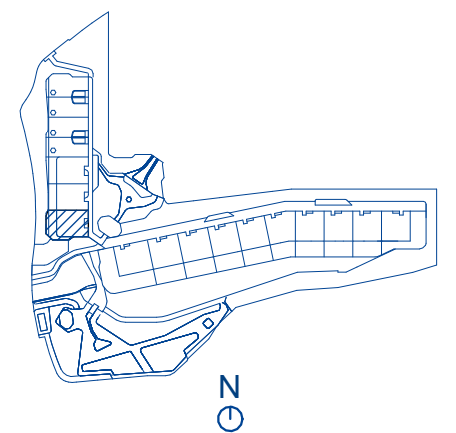
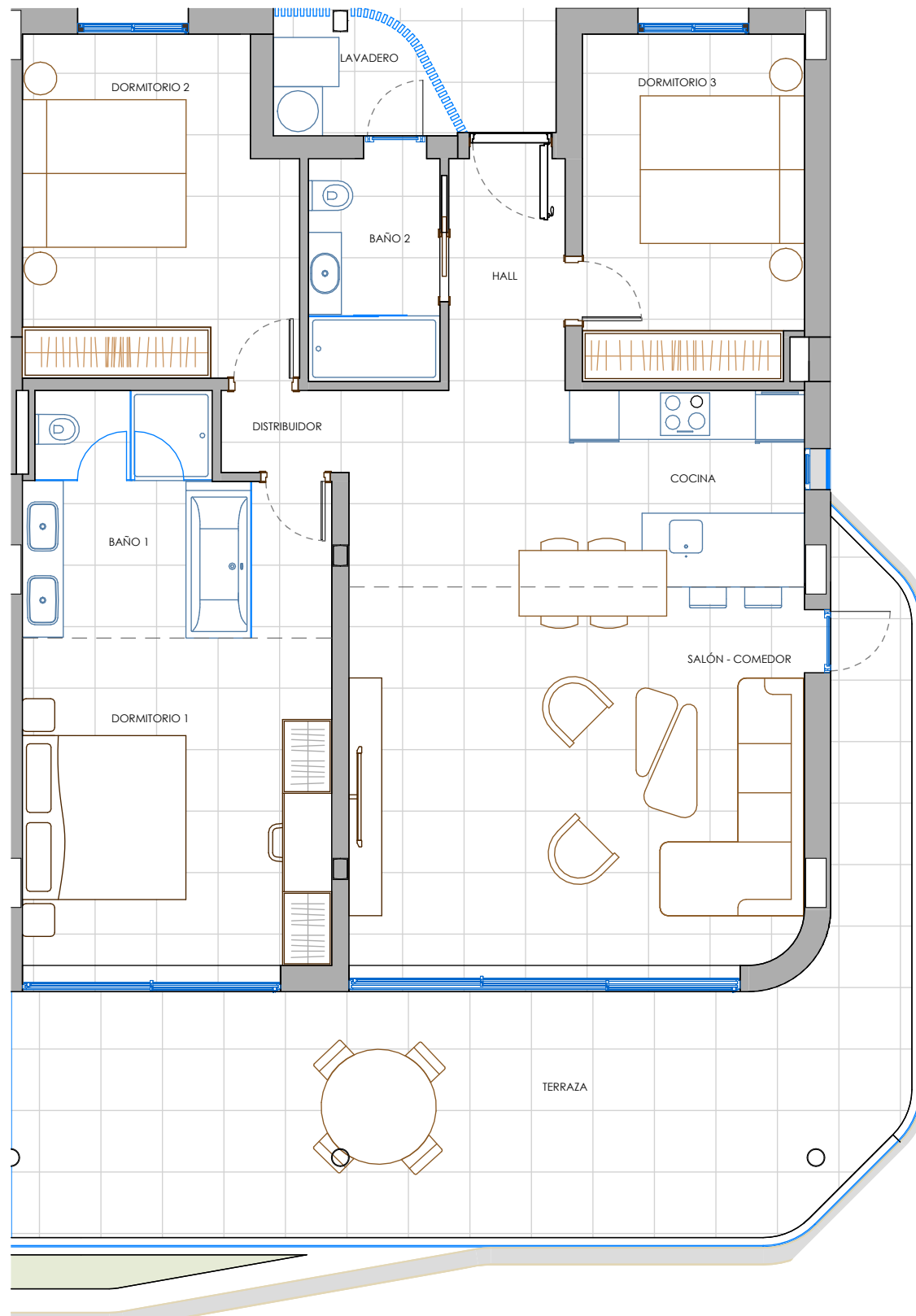

VIRGINIA (Módulo D1)  
P2 G  
Apartamento nº 179

SUPERFICIE CONSTRUIDA VIVIENDA..... 117.47 m<sup>2</sup>

SUPERFICIE CONSTRUIDA TERRAZA..... 43.12 m<sup>2</sup>

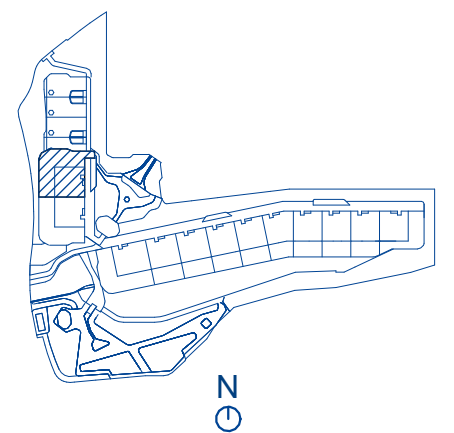
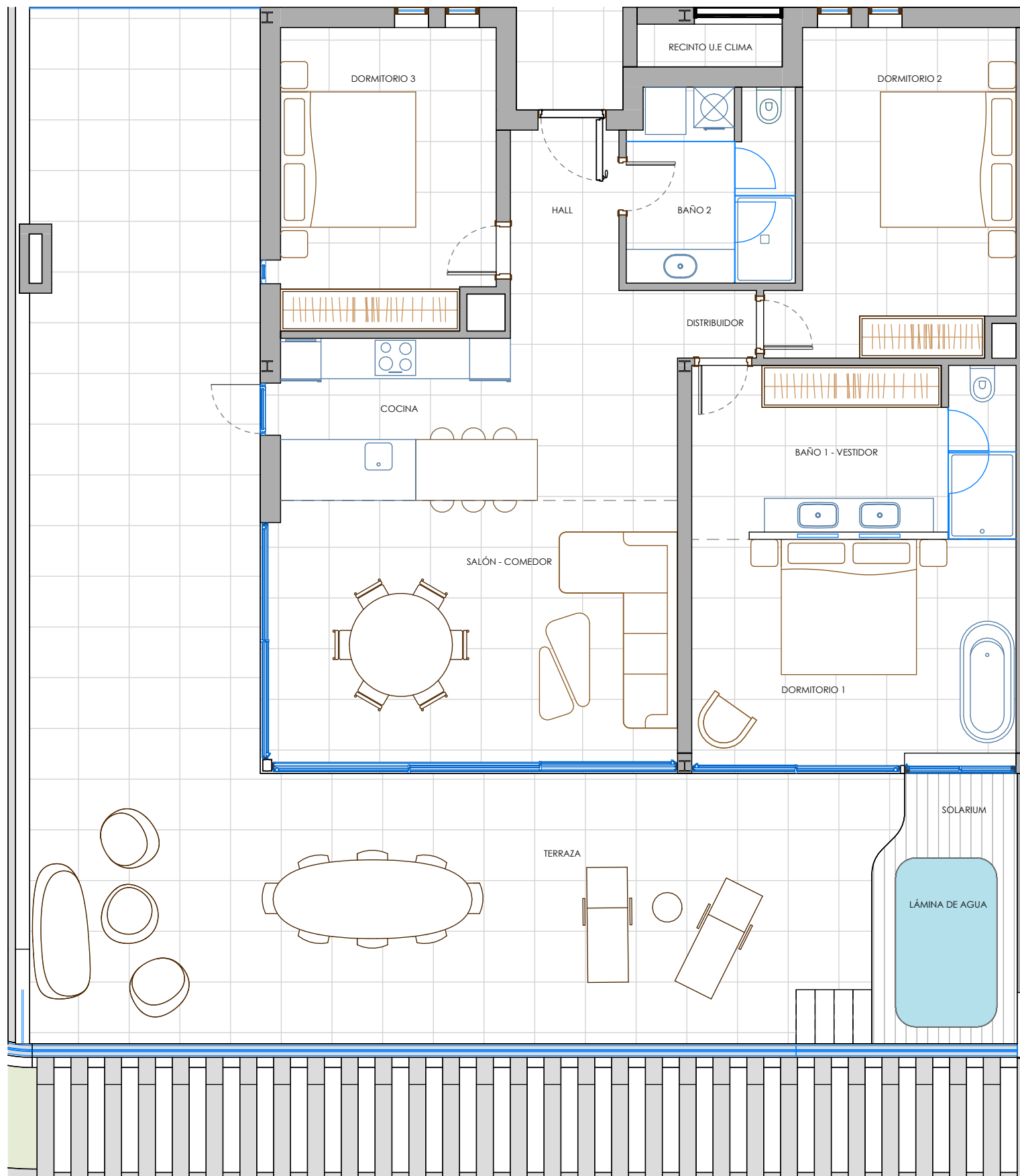

VIRGINIA (Módulo D1)  
Ático A  
Apartamento nº 180

SUPERFICIE CONSTRUIDA VIVIENDA.....	125.95 m <sup>2</sup>
SUPERFICIE CONSTRUIDA TERRAZA.....	95.04 m <sup>2</sup>
SUPERFICIE LÁMINA DE AGUA & SOLARIUM....	8.10 m <sup>2</sup>
<b>SUPERFICIE EXTERIOR TOTAL</b>	<b>104.04 m<sup>2</sup></b>

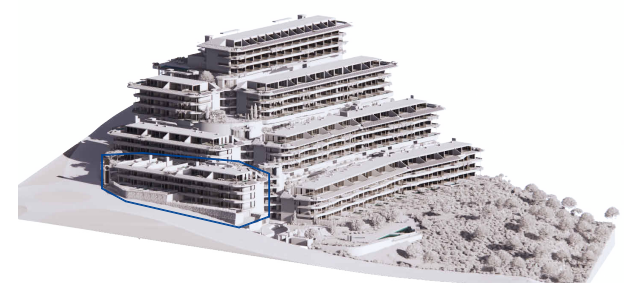

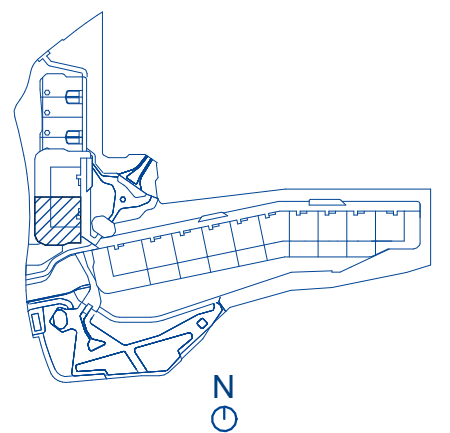
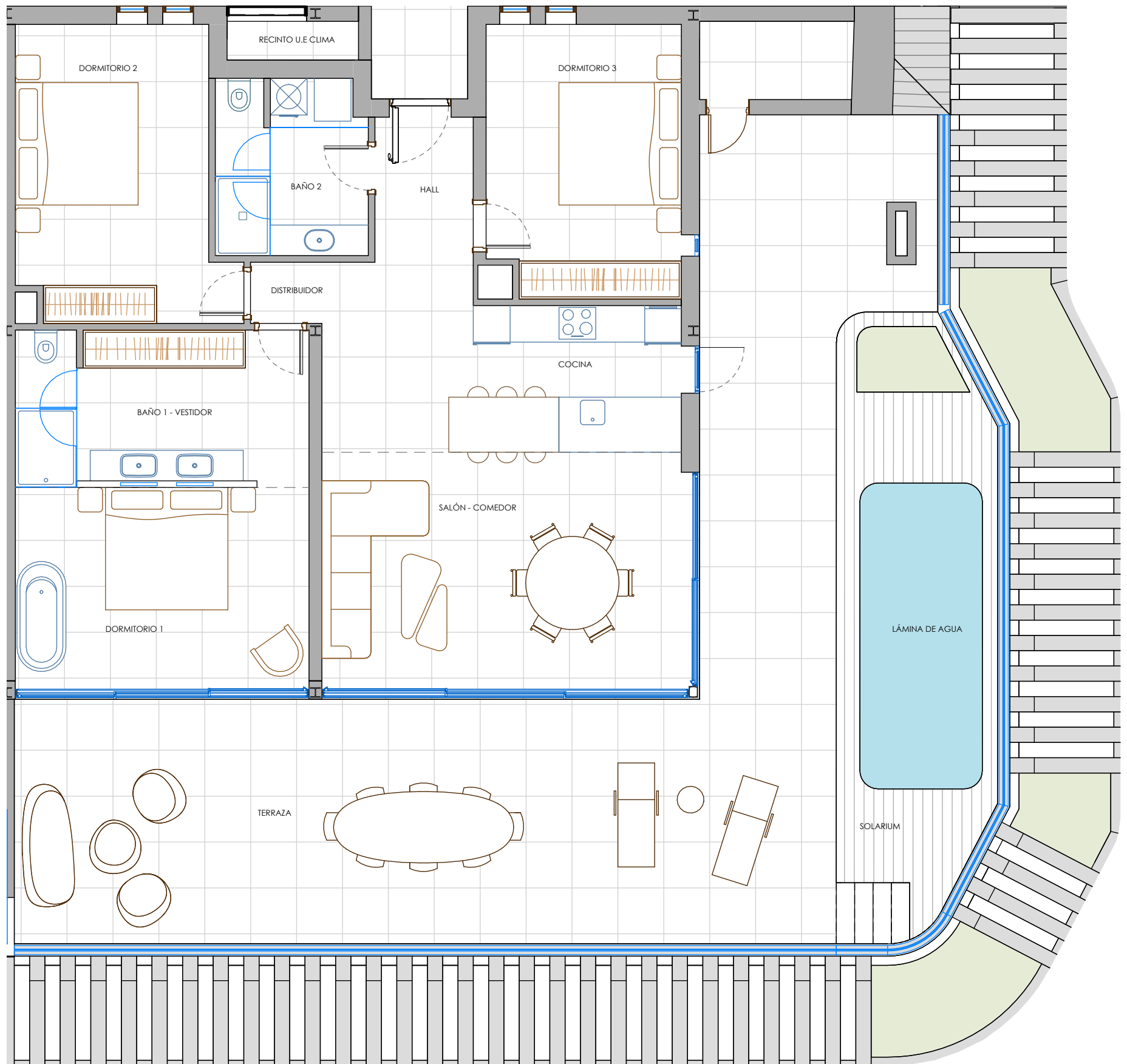

VIRGINIA (Módulo D1)  
Ático B  
Apartamento nº 181

SUPERFICIE CONSTRUIDA VIVIENDA.....	125.97 m <sup>2</sup>
SUPERFICIE CONSTRUIDA TERRAZA.....	87.97 m <sup>2</sup>
SUPERFICIE LÁMINA DE AGUA & SOLARIUM.....	23.62 m <sup>2</sup>
<b>SUPERFICIE EXTERIOR TOTAL</b>	<b>111.59 m<sup>2</sup></b>

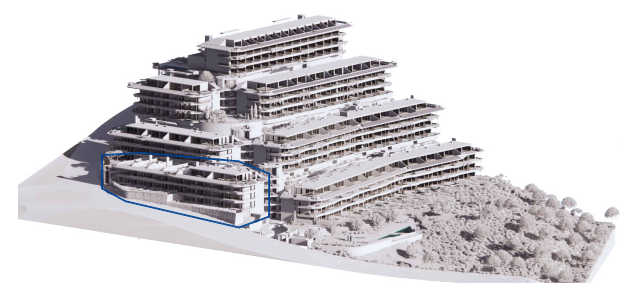

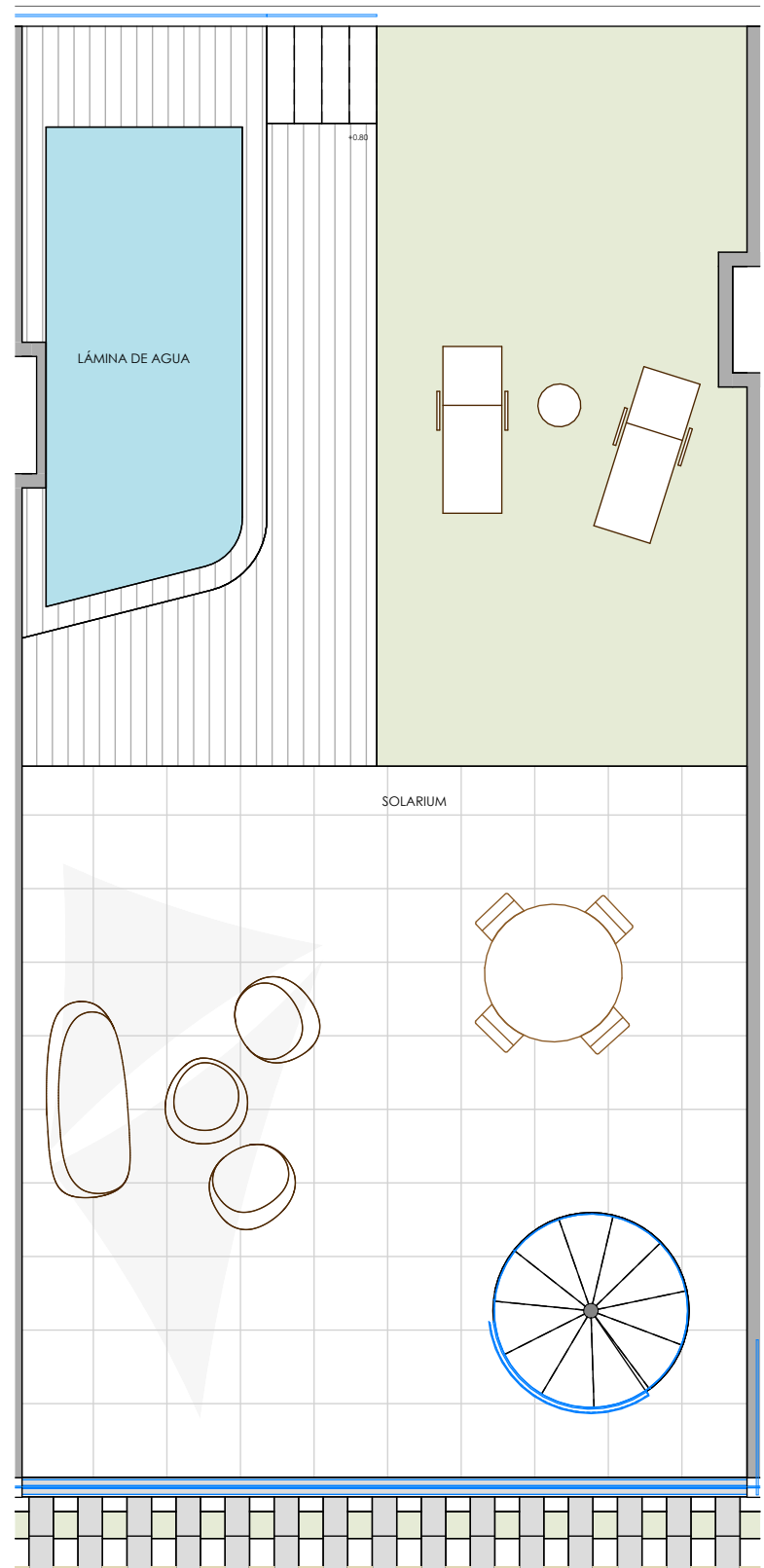
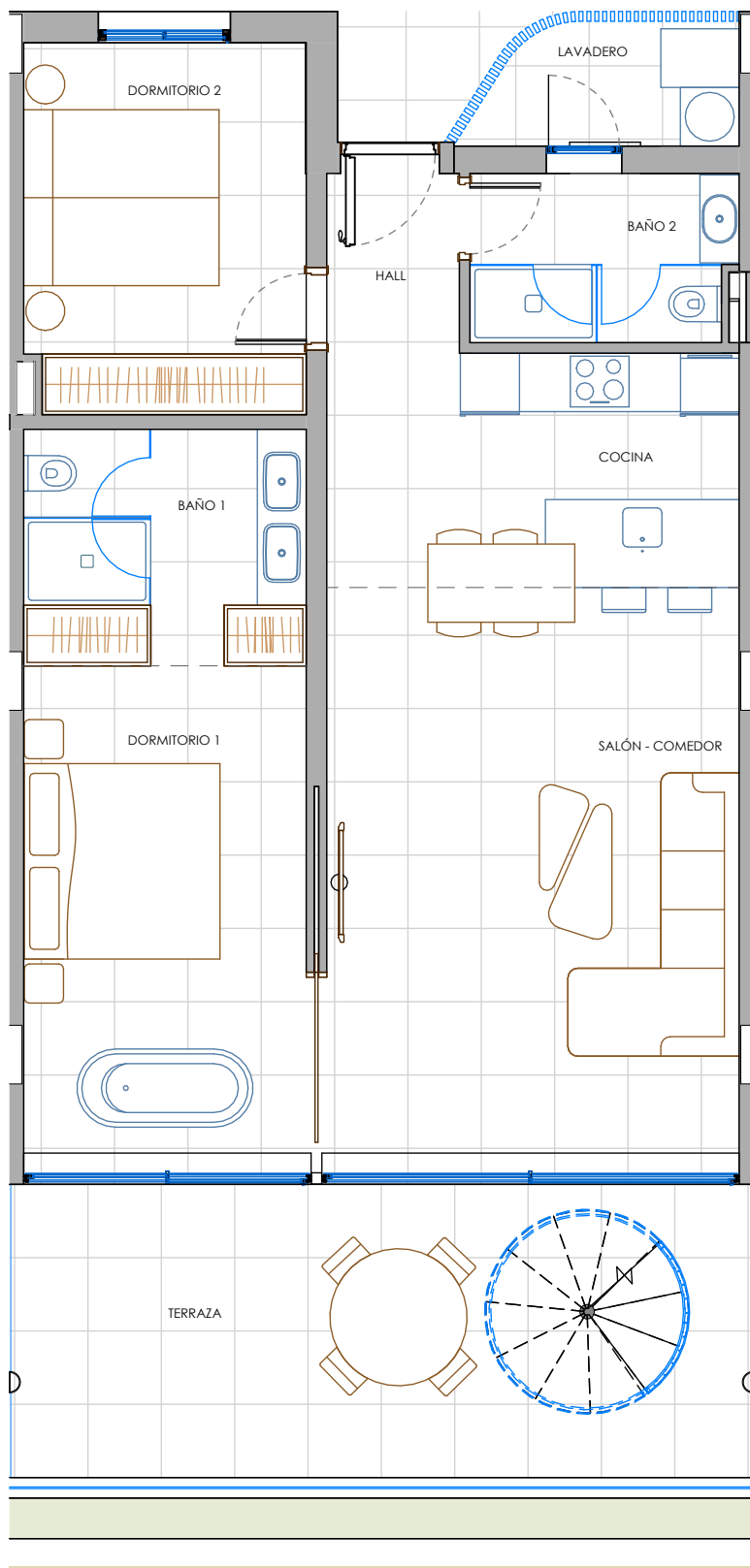

VIRGINIA (Módulo D1)  
ÁTICO SOLARIUM B  
Apartamento nº 171

SUPERFICIE CONSTRUIDA VIVIENDA.....88.83 m<sup>2</sup>  
 SUPERFICIE CONSTRUIDA TERRAZA.....24.39 m<sup>2</sup>  
 SUPERFICIE LÁMINA DE AGUA & SOLARIUM....115.52 m<sup>2</sup>  
 SUPERFICIE EXTERIOR TOTAL 139.91 m<sup>2</sup>

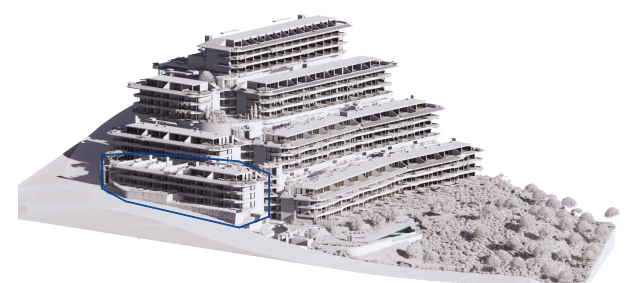
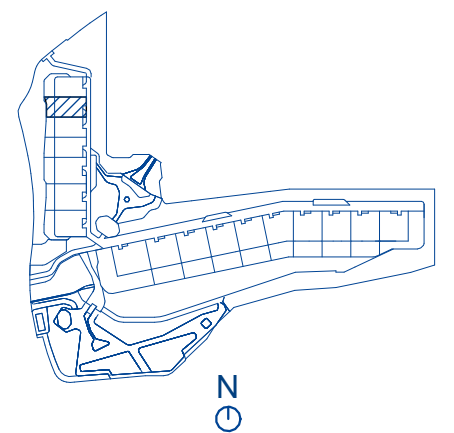

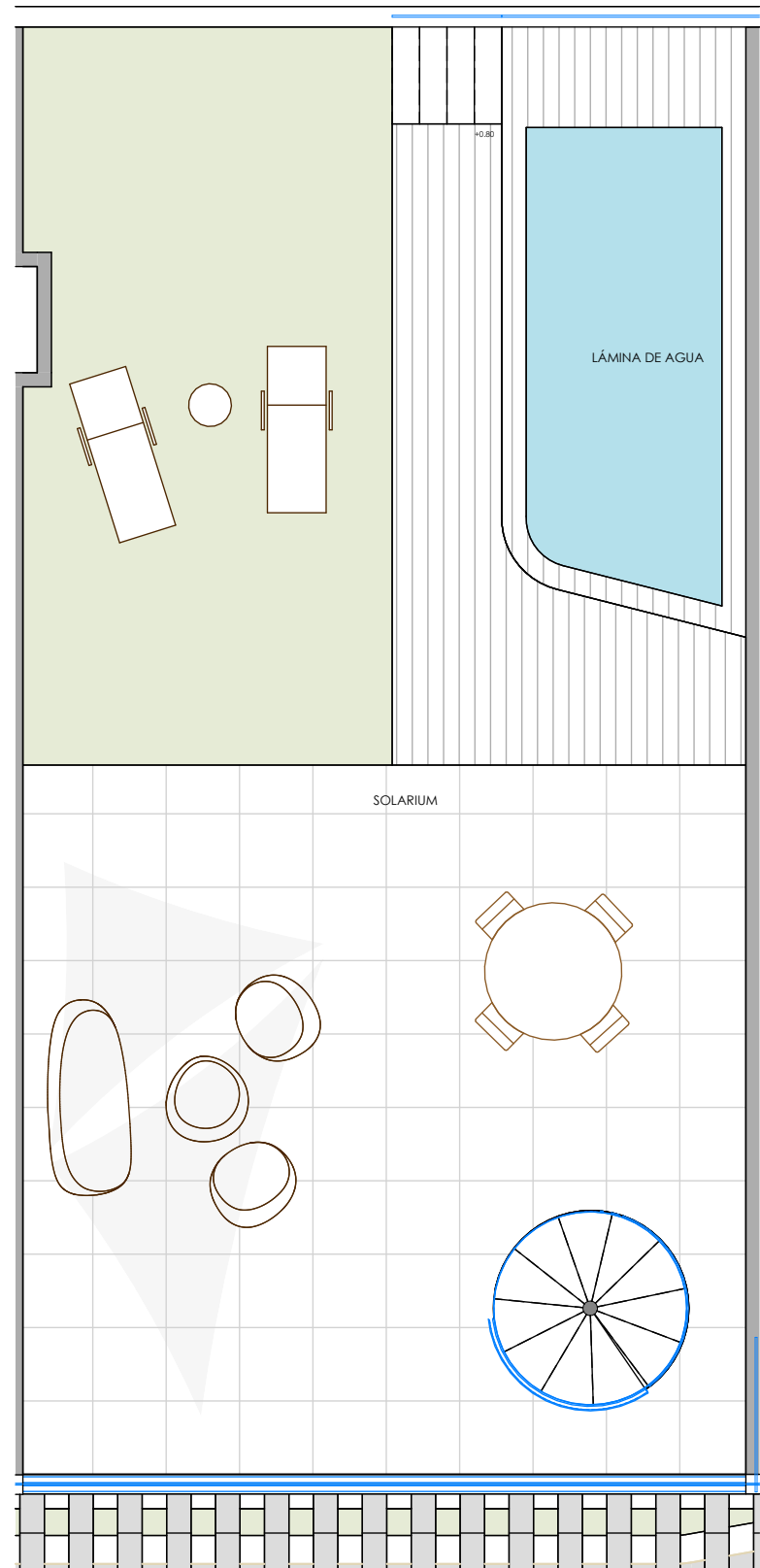
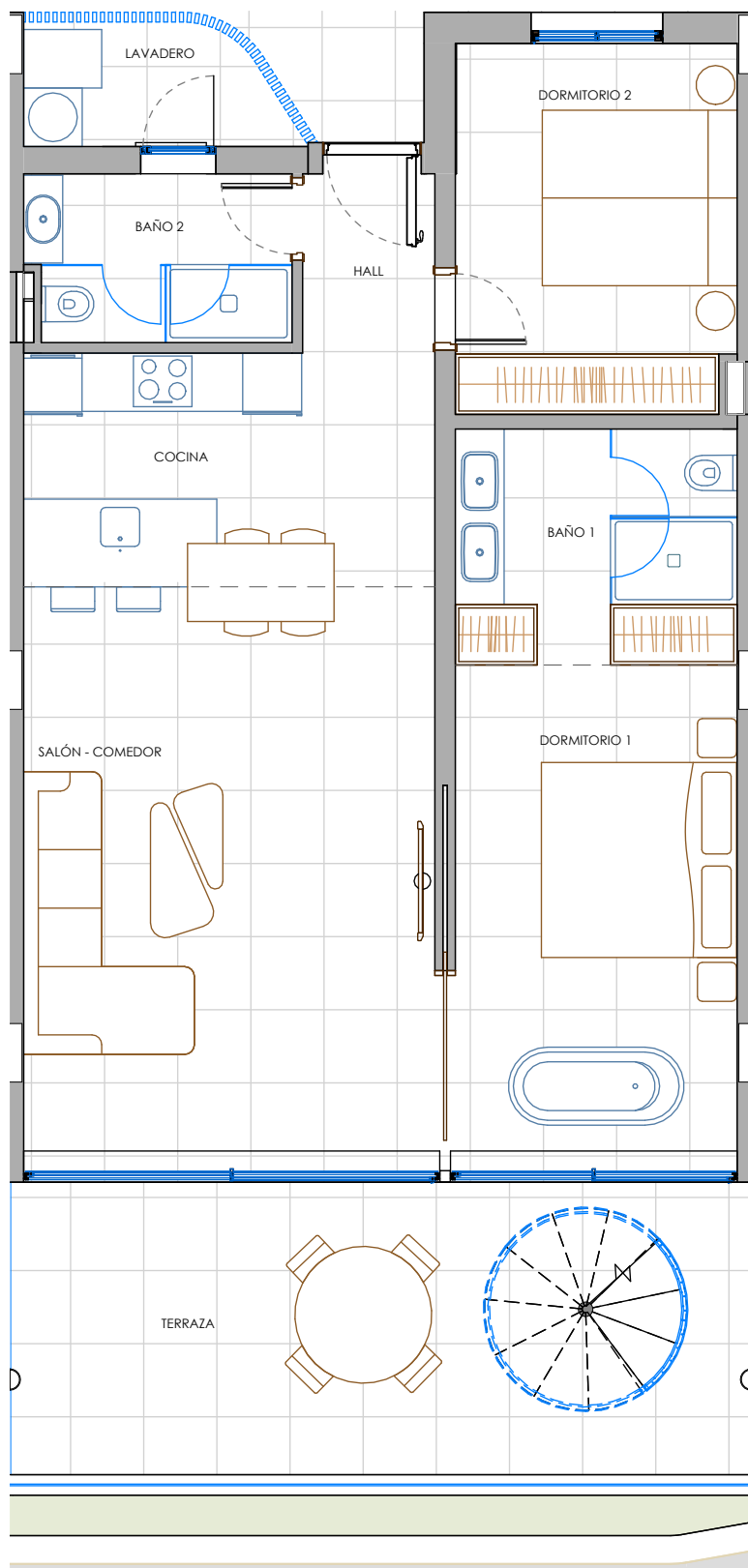

VIRGINIA (Módulo D1)  
ÁTICO SOLARIUM C  
Apartamento nº 172

SUPERFICIE CONSTRUIDA VIVIENDA.....88.83 m<sup>2</sup>  
 SUPERFICIE CONSTRUIDA TERRAZA.....24.39 m<sup>2</sup>  
 SUPERFICIE LÁMINA DE AGUA & SOLARIUM....115.52 m<sup>2</sup>  
 SUPERFICIE EXTERIOR TOTAL 139.91 m<sup>2</sup>

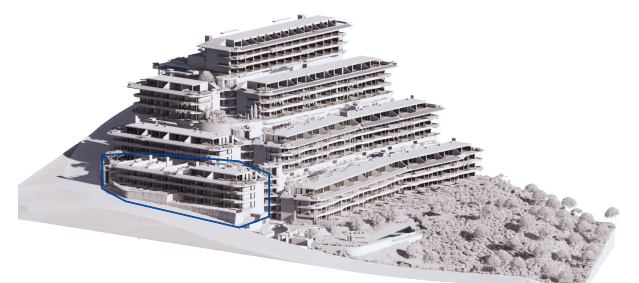
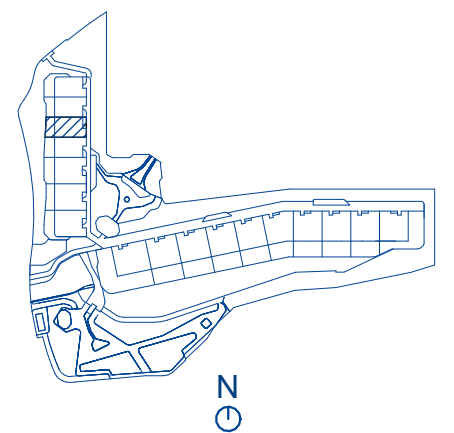



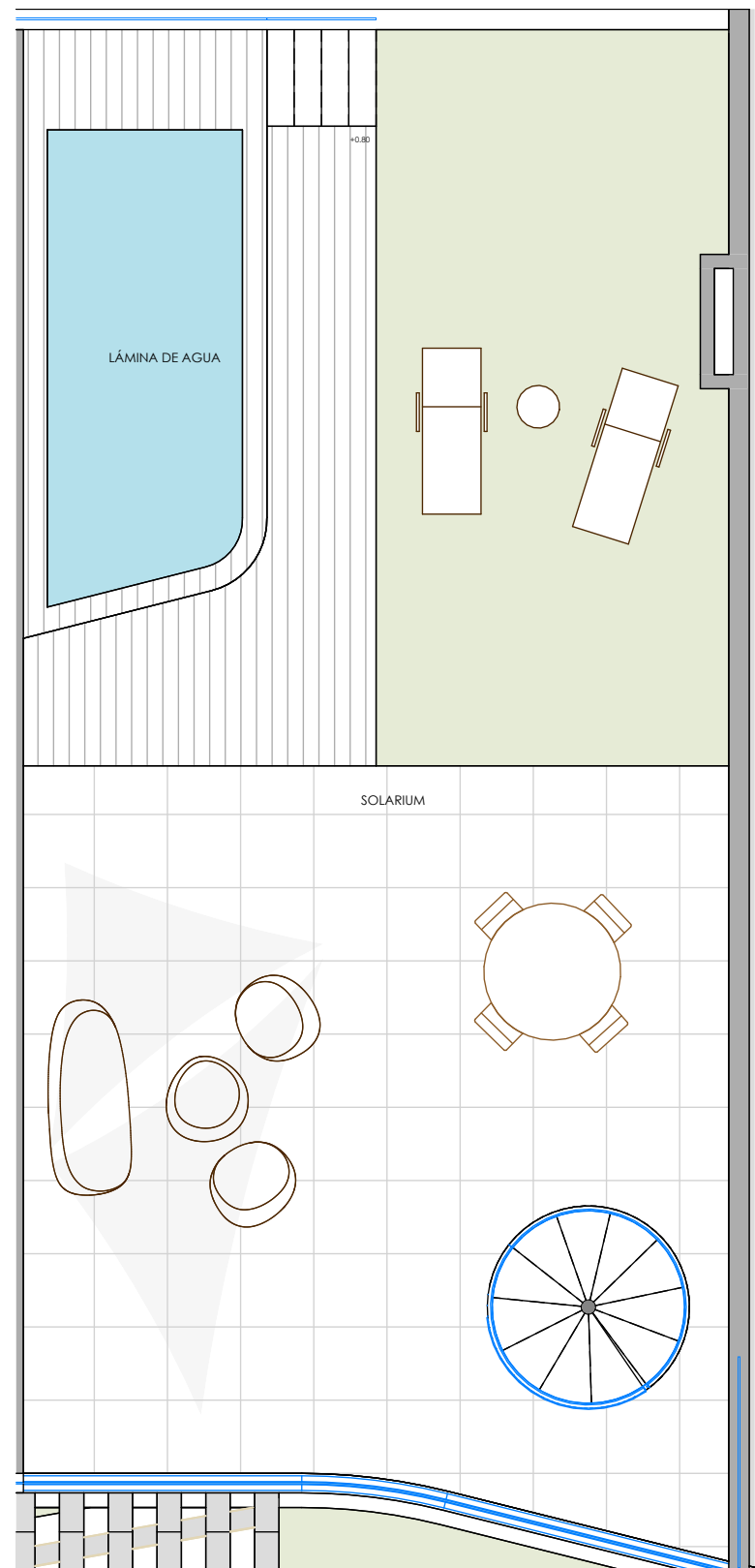
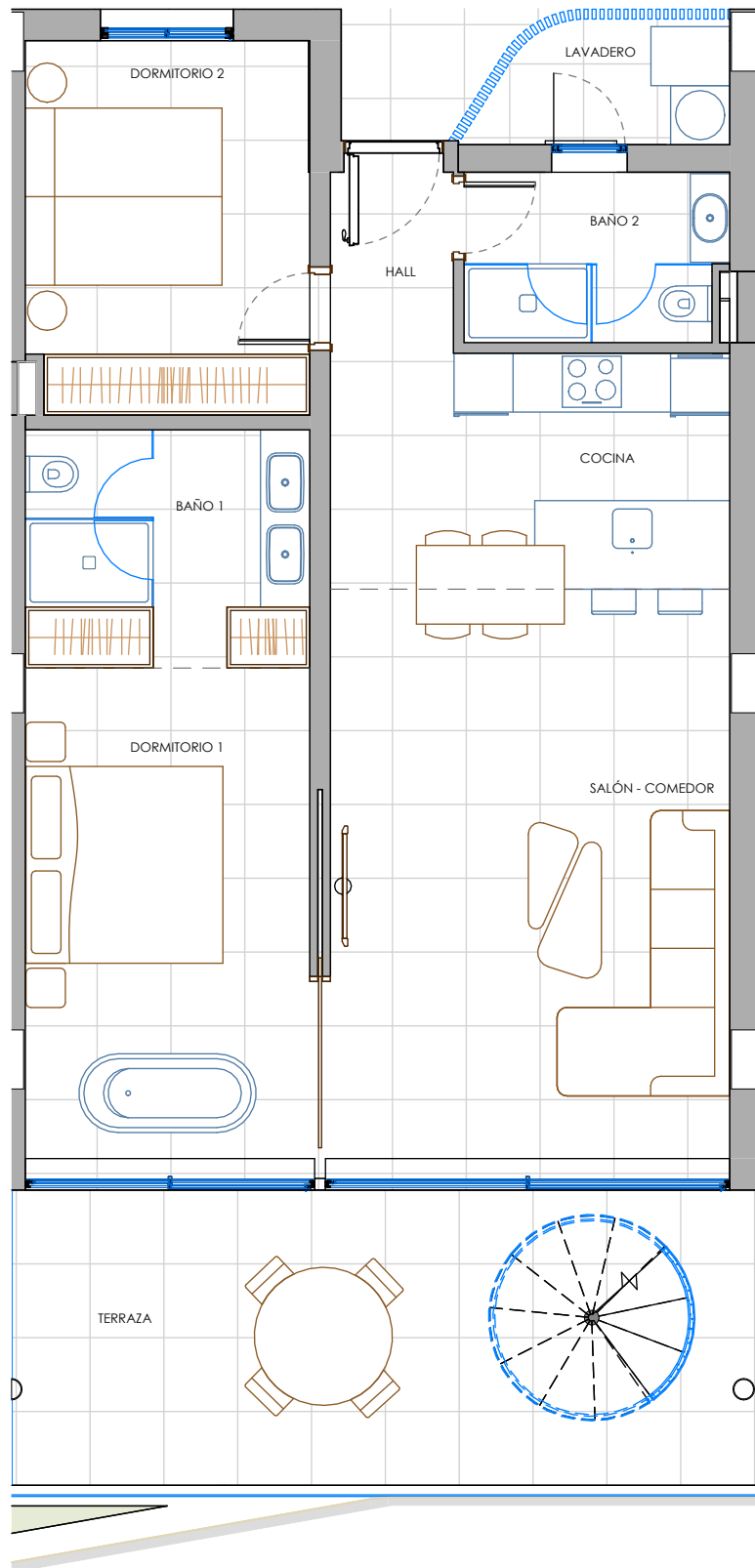

VIRGINIA (Módulo D1)  
ÁTICO SOLARIUM D  
Apartamento nº 173

SUPERFICIE CONSTRUIDA VIVIENDA.....	89.13 m <sup>2</sup>
SUPERFICIE CONSTRUIDA TERRAZA.....	24.85 m <sup>2</sup>
SUPERFICIE LÁMINA DE AGUA & SOLARIUM....	118.09 m <sup>2</sup>
<b>SUPERFICIE EXTERIOR TOTAL</b>	<b>142.94 m<sup>2</sup></b>

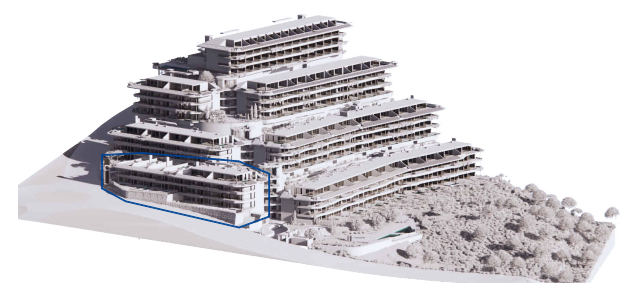
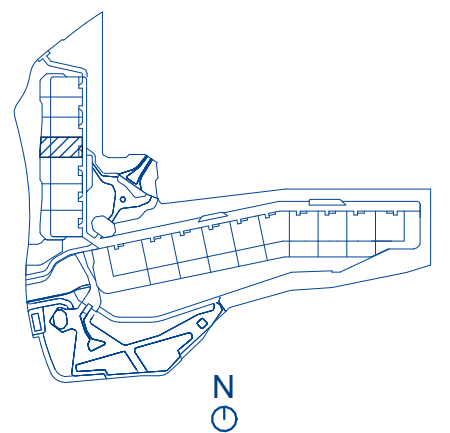

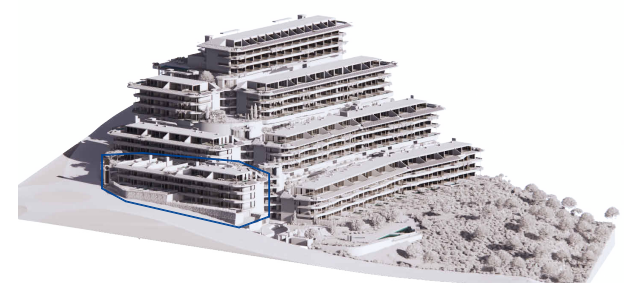
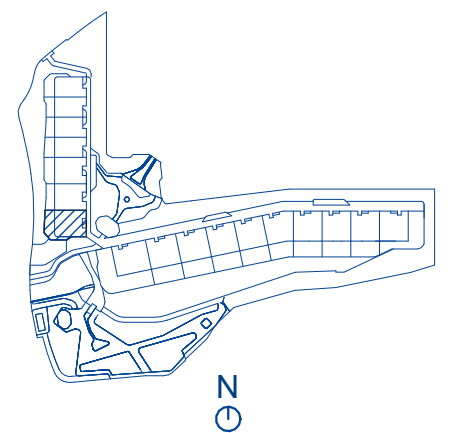
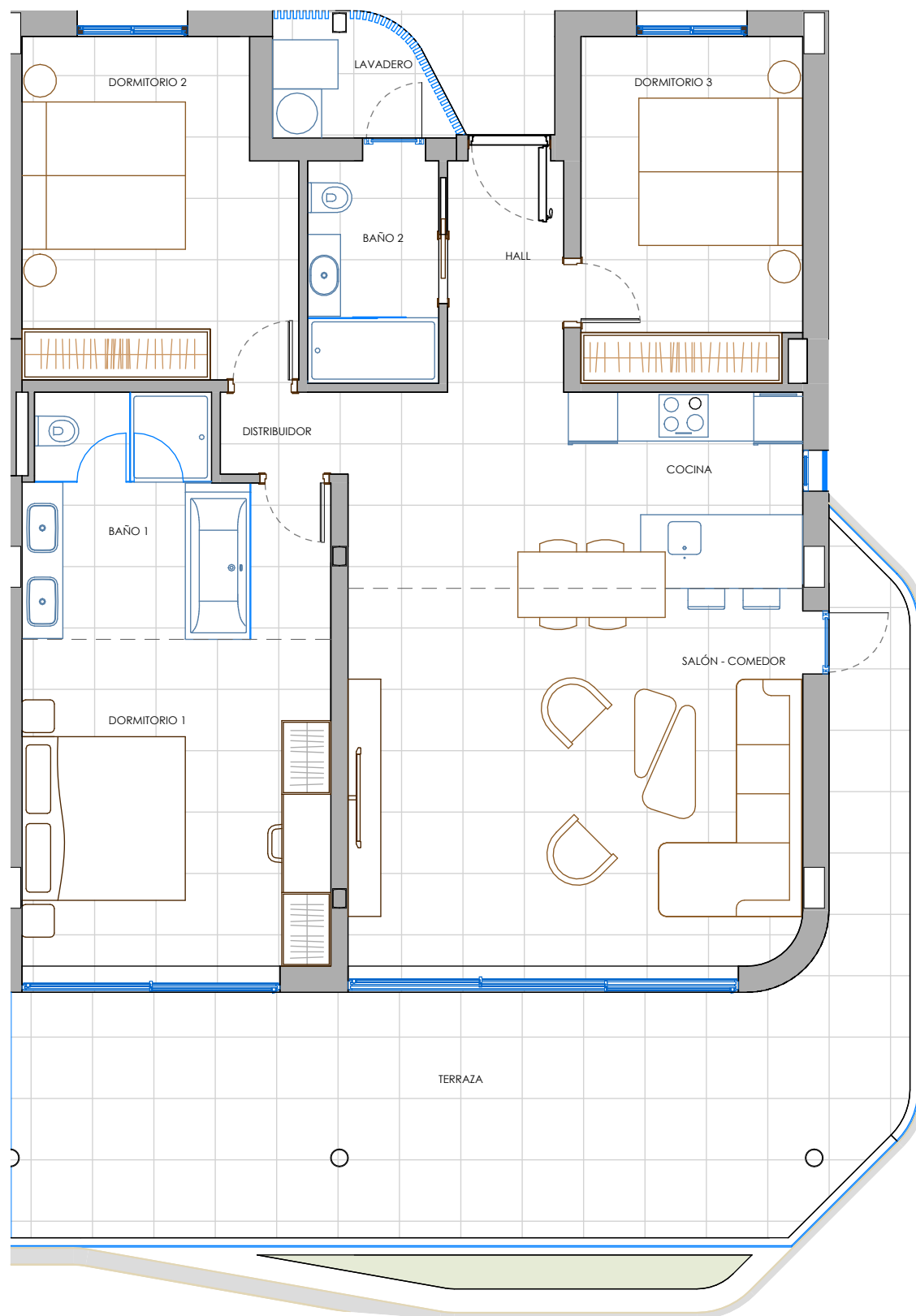

VIRGINIA (Módulo D1)  
P1 G  
Apartamento nº 176

SUPERFICIE CONSTRUIDA VIVIENDA..... 117.57 m<sup>2</sup>  
SUPERFICIE CONSTRUIDA TERRAZA..... 42.78 m<sup>2</sup>

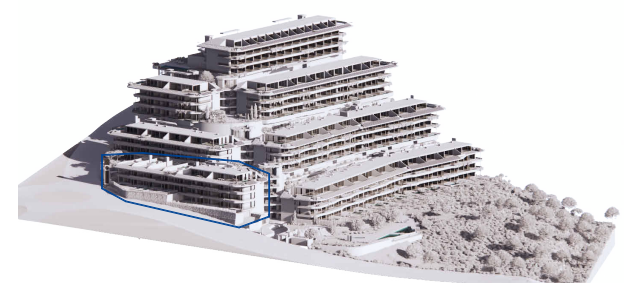
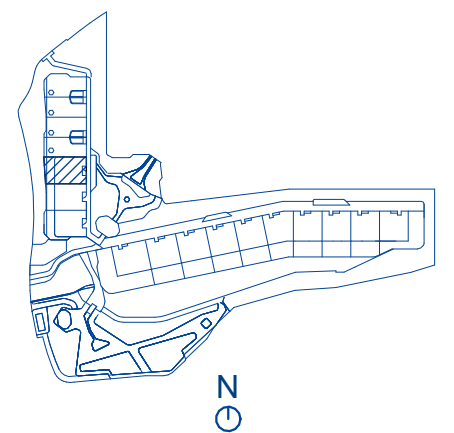
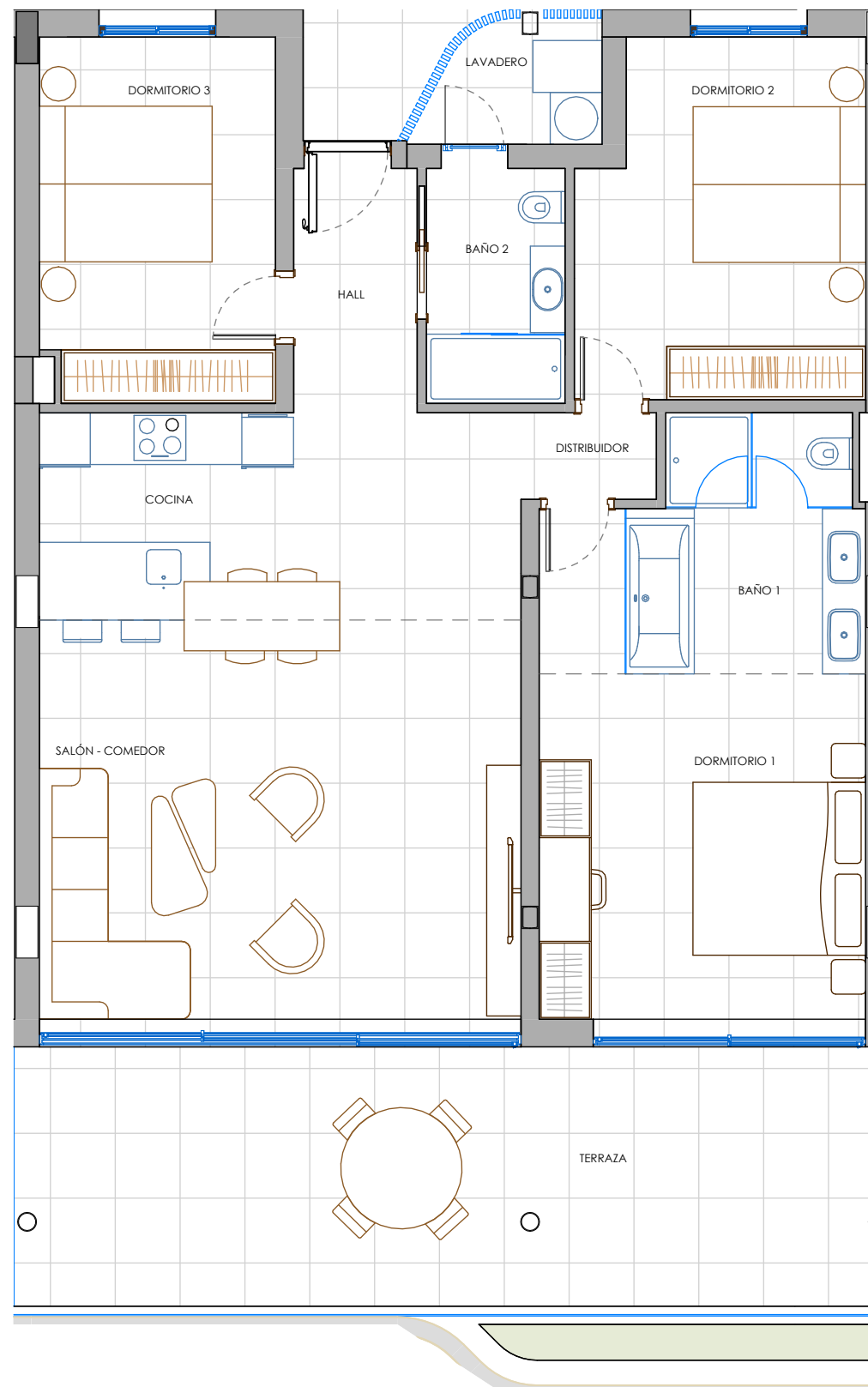

VIRGINIA (Módulo D1)  
P2 E  
Apartamento nº 177

SUPERFICIE CONSTRUIDA VIVIENDA..... 117.67 m<sup>2</sup>

SUPERFICIE CONSTRUIDA TERRAZA..... 32.64 m<sup>2</sup>

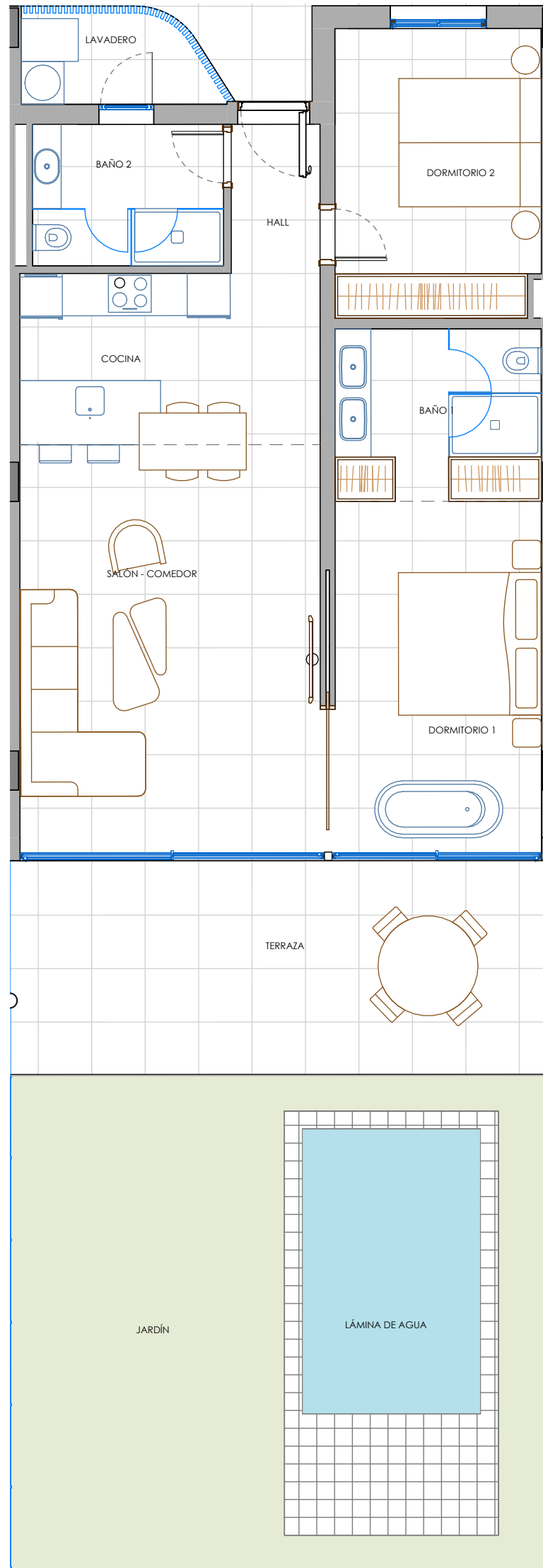

NIÁGARA (Módulo D2)  
Garden Villa G  
Apartamento nº 188

SUPERFICIE CONSTRUIDA VIVIENDA.....	89.03 m <sup>2</sup>
SUPERFICIE CONSTRUIDA TERRAZA.....	22.90 m <sup>2</sup>
SUPERFICIE JARDÍN.....	35.34 m <sup>2</sup>
SUPERFICIE LÁMINA & PLAYA PISCINA.....	17.85 m <sup>2</sup>
<b>SUPERFICIE EXTERIOR TOTAL</b>	<b>76.09 m<sup>2</sup></b>

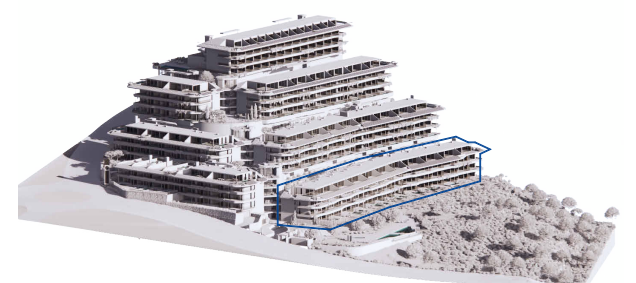
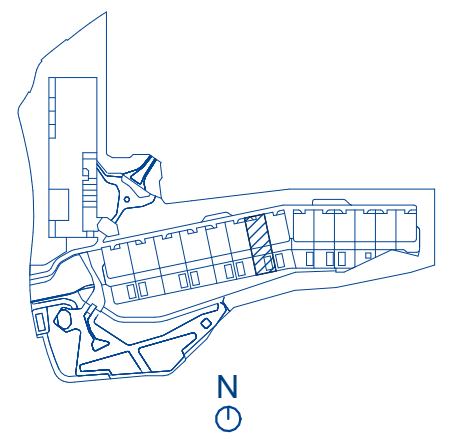

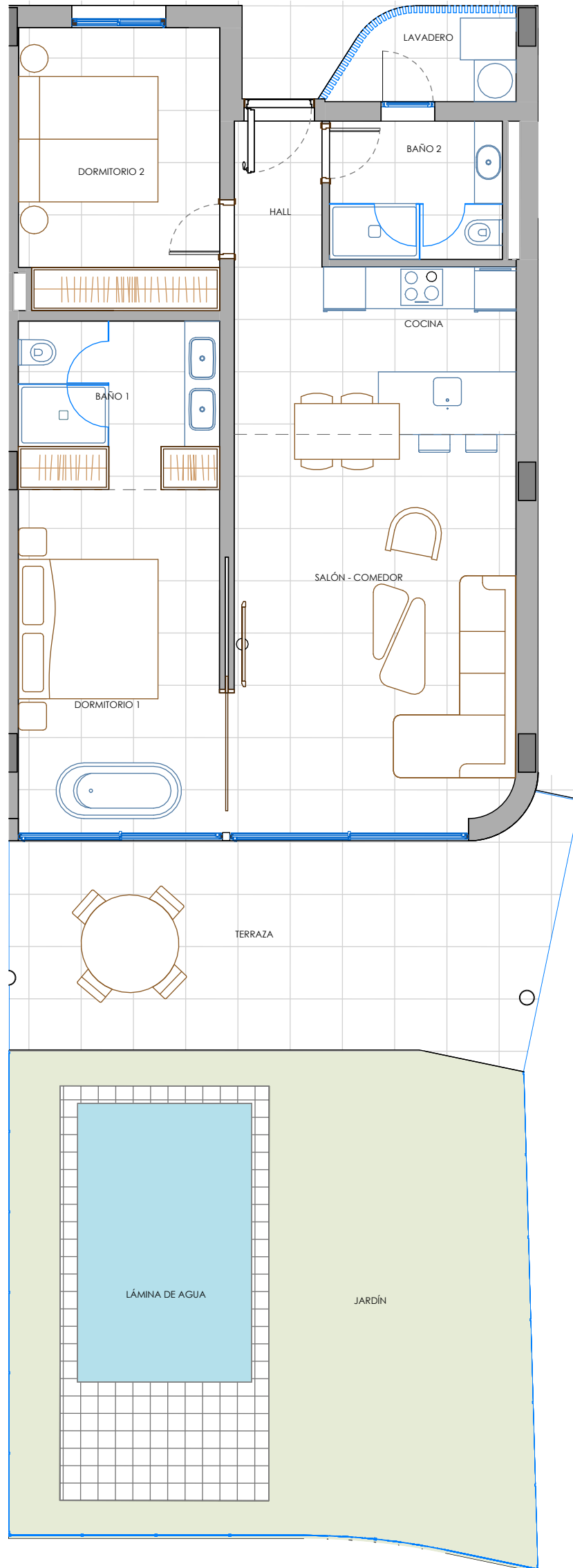

NIÁGARA (Módulo D2)  
Garden Villa H  
Apartamento nº 189

SUPERFICIE CONSTRUIDA VIVIENDA.....	88.84 m <sup>2</sup>
SUPERFICIE CONSTRUIDA TERRAZA.....	24.23 m <sup>2</sup>
SUPERFICIE JARDÍN.....	35.01 m <sup>2</sup>
SUPERFICIE LÁMINA & PLAYA PISCINA.....	17.85 m <sup>2</sup>
<b>SUPERFICIE EXTERIOR TOTAL</b>	<b>77.09 m<sup>2</sup></b>

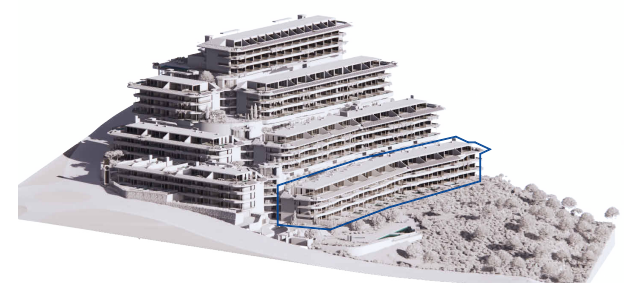
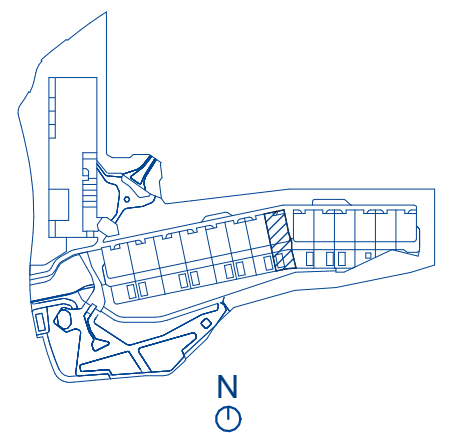

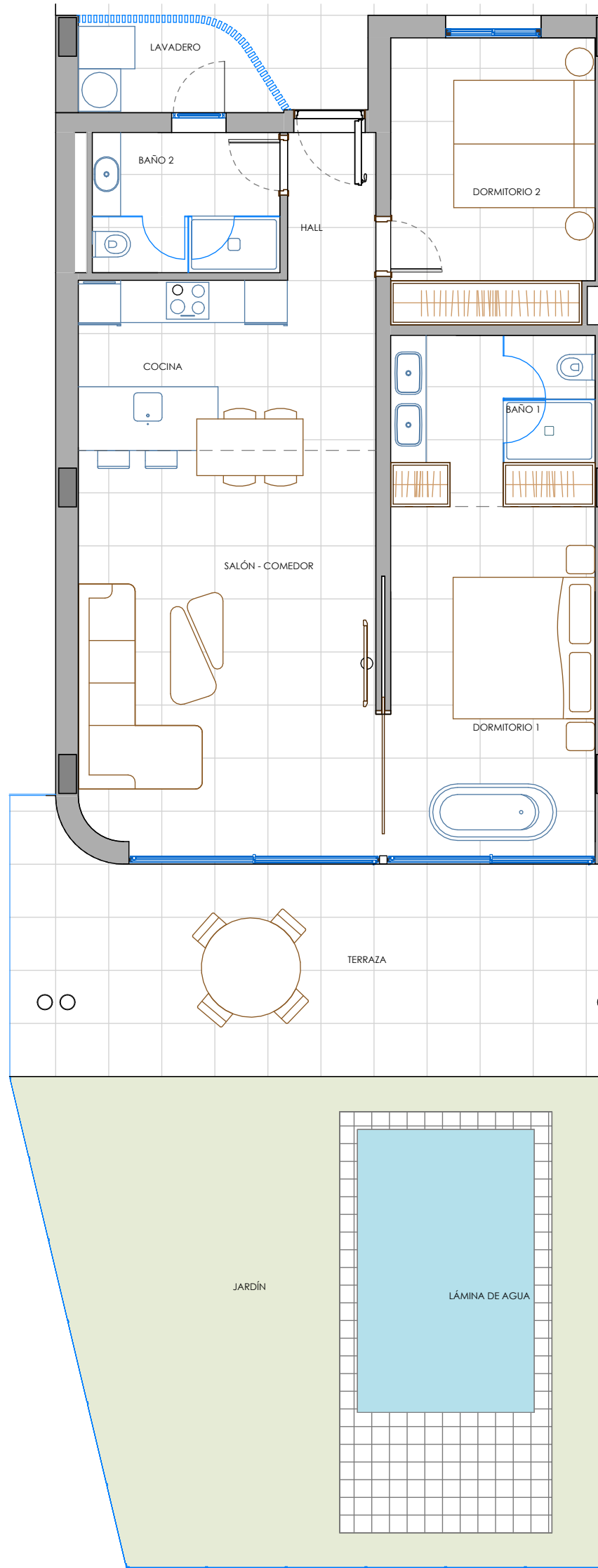

NIÁGARA (Módulo D2)  
Garden Villa I  
Apartamento nº 190

SUPERFICIE CONSTRUIDA VIVIENDA.....	90.94 m <sup>2</sup>
SUPERFICIE CONSTRUIDA TERRAZA.....	26.17 m <sup>2</sup>
SUPERFICIE JARDÍN.....	35.29 m <sup>2</sup>
SUPERFICIE LÁMINA & PLAYA PISCINA.....	17.85 m <sup>2</sup>
<b>SUPERFICIE EXTERIOR TOTAL</b>	<b>79.31 m<sup>2</sup></b>

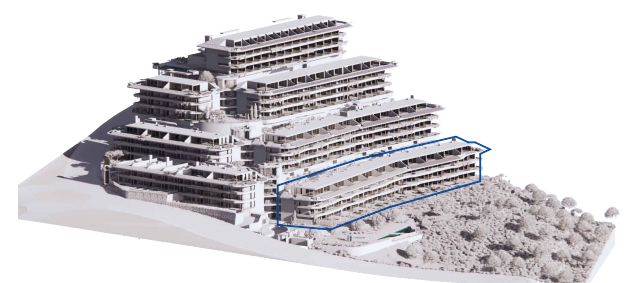
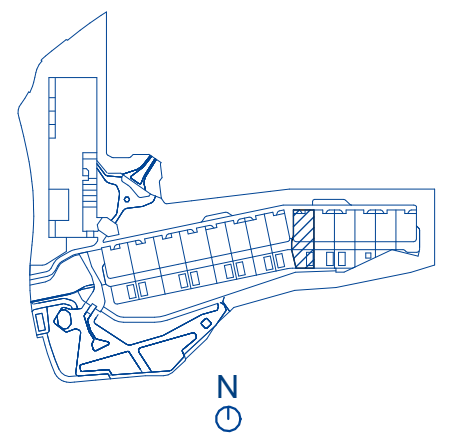

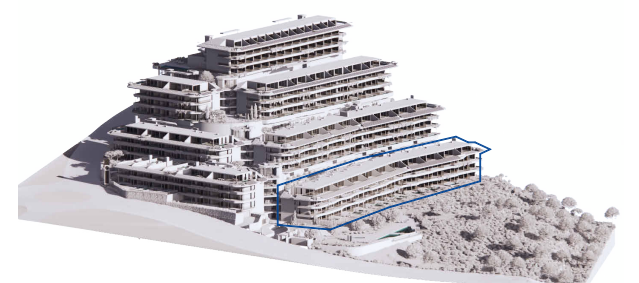
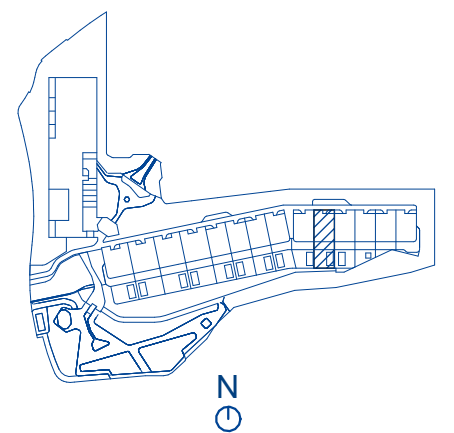
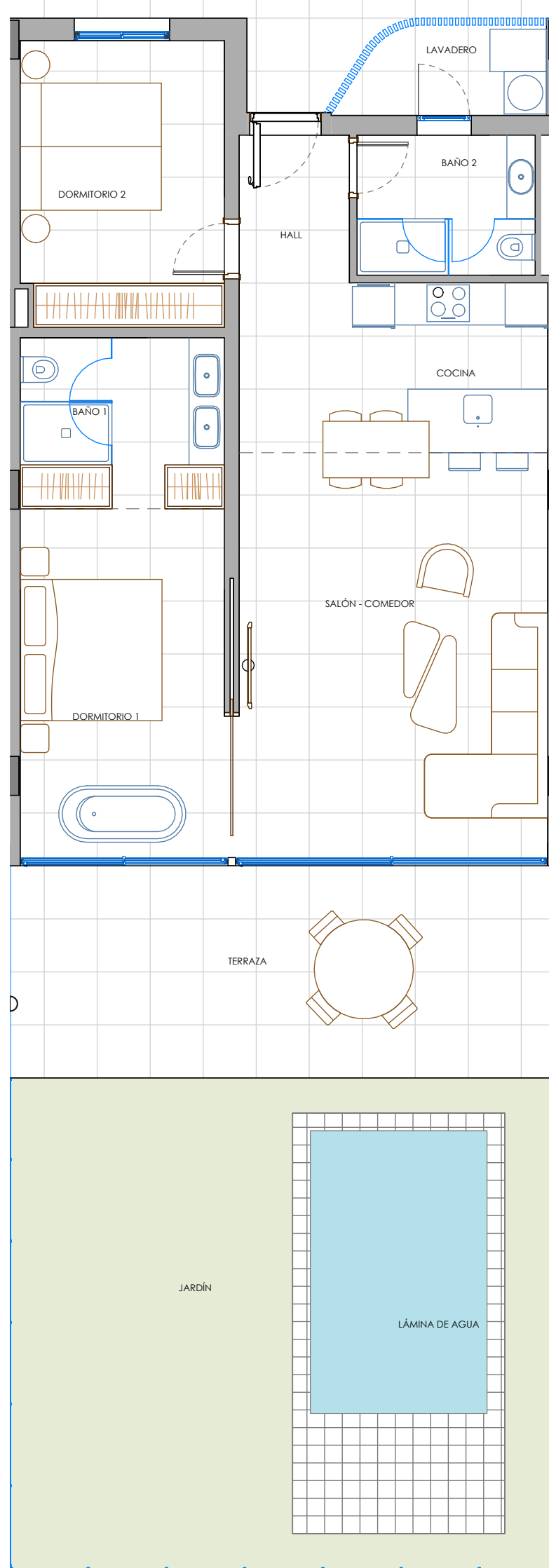

NIÁGARA (Módulo D2)  
Garden Villa J  
Apartamento nº 191

SUPERFICIE CONSTRUIDA VIVIENDA.....	90.89 m <sup>2</sup>
SUPERFICIE CONSTRUIDA TERRAZA.....	23.25 m <sup>2</sup>
SUPERFICIE JARDÍN.....	36.36 m <sup>2</sup>
SUPERFICIE LÁMINA & PLAYA PISCINA.....	17.85 m <sup>2</sup>
<b>SUPERFICIE EXTERIOR TOTAL</b>	<b>77.46 m<sup>2</sup></b>



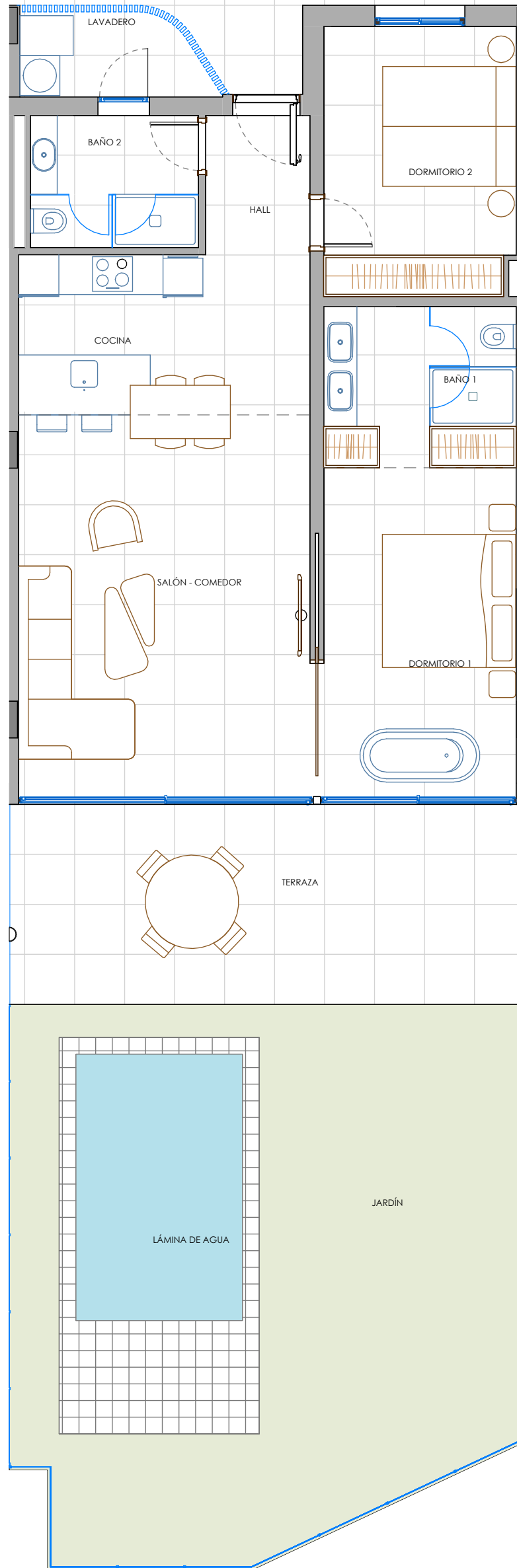

NIÁGARA (Módulo D2)  
Garden Villa K  
Apartamento nº 192

SUPERFICIE CONSTRUIDA VIVIENDA.....	90.97 m <sup>2</sup>
SUPERFICIE CONSTRUIDA TERRAZA.....	23.27 m <sup>2</sup>
SUPERFICIE JARDÍN.....	43.23 m <sup>2</sup>
SUPERFICIE LÁMINA & PLAYA PISCINA.....	17.85 m <sup>2</sup>
<b>SUPERFICIE EXTERIOR TOTAL</b>	<b>84.35 m<sup>2</sup></b>

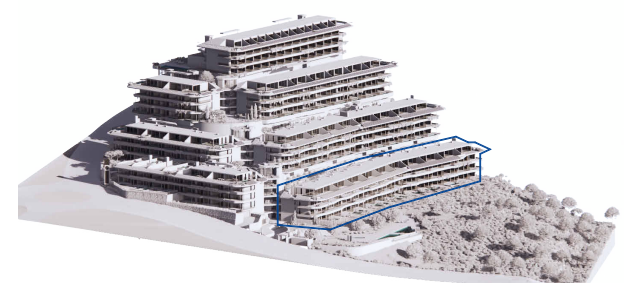
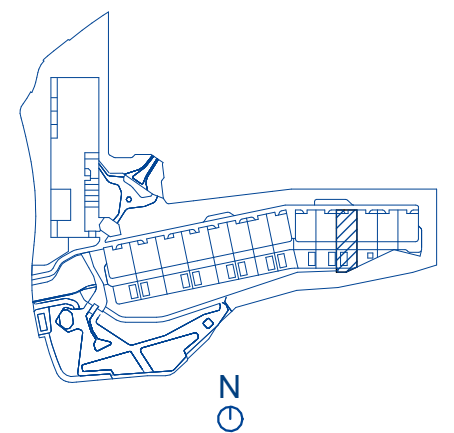

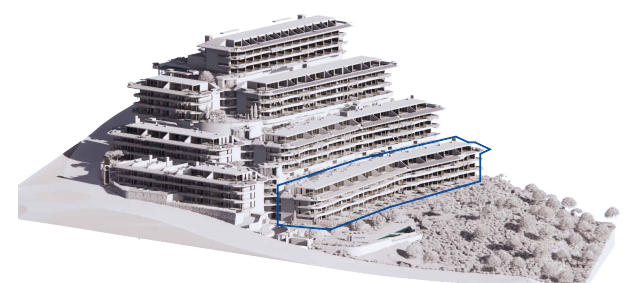
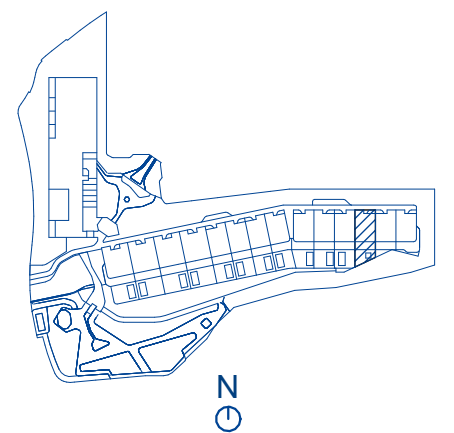
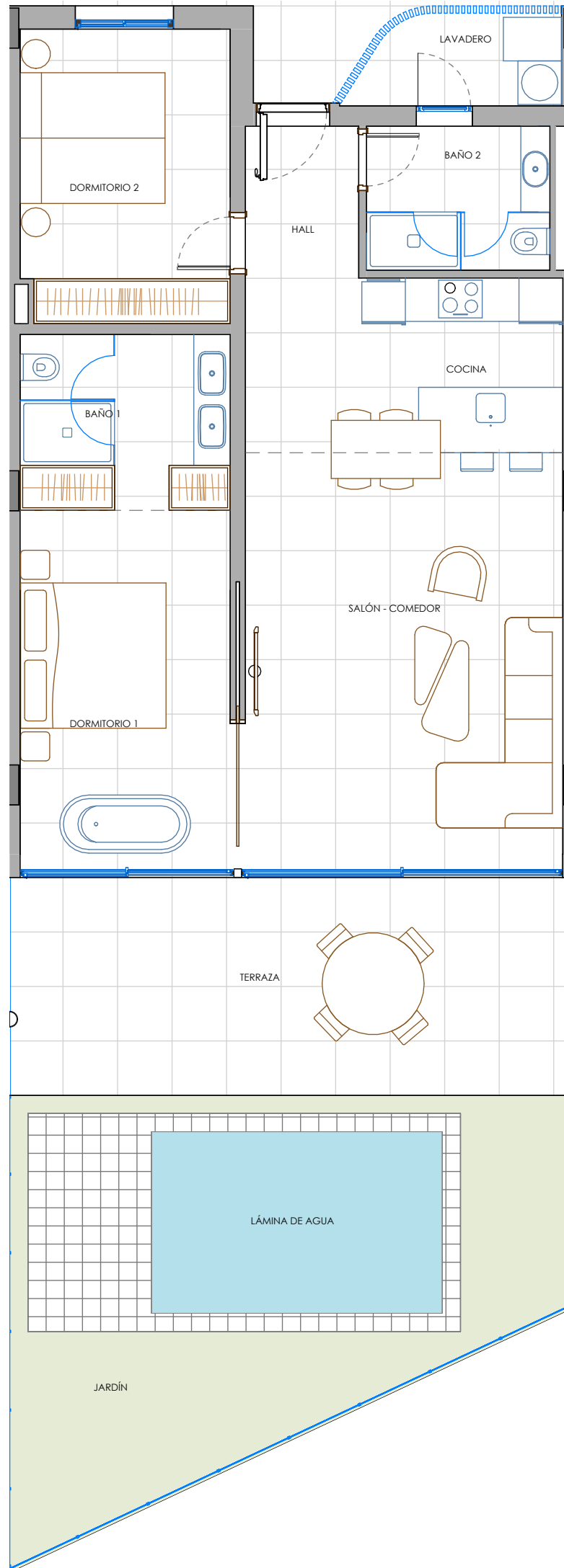

NIÁGARA (Módulo D2)  
Garden Villa L  
Apartamento nº 193

SUPERFICIE CONSTRUIDA VIVIENDA.....	90.87 m <sup>2</sup>
SUPERFICIE CONSTRUIDA TERRAZA.....	23.24 m <sup>2</sup>
SUPERFICIE JARDÍN.....	18.95 m <sup>2</sup>
SUPERFICIE LÁMINA & PLAYA PISCINA.....	17.85 m <sup>2</sup>
<b>SUPERFICIE EXTERIOR TOTAL</b>	<b>60.04 m<sup>2</sup></b>

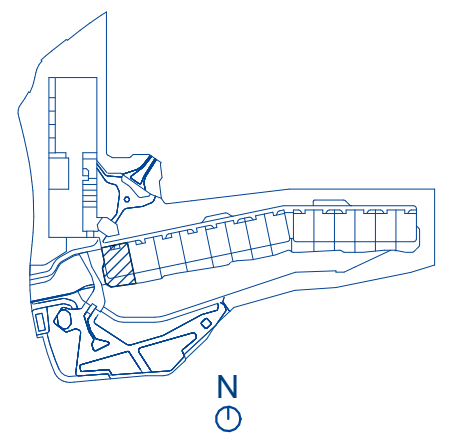
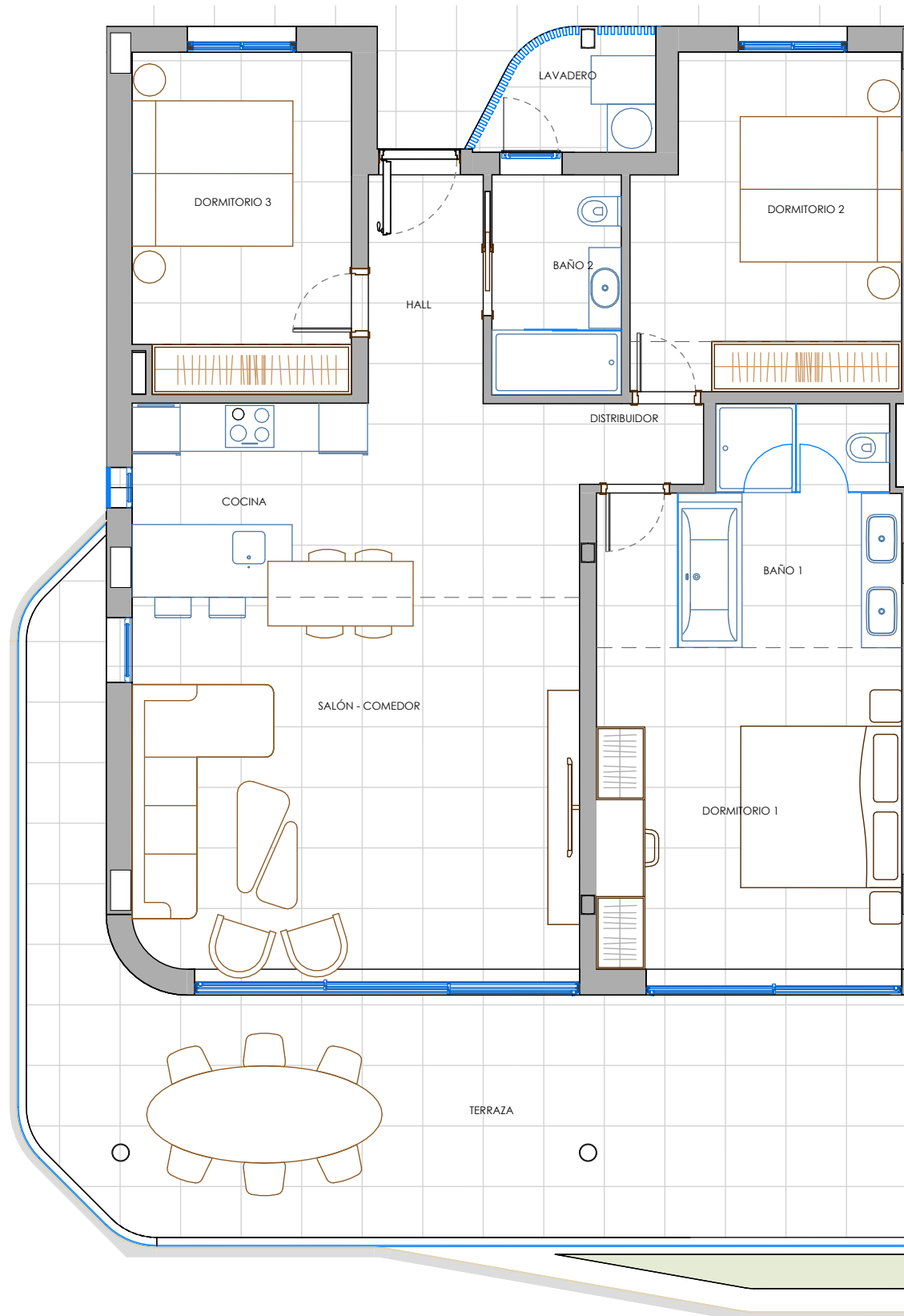

NIÁGARA (Módulo D2)  
P1 A  
Apartamento nº 196

SUPERFICIE CONSTRUIDA VIVIENDA..... 117.33 m<sup>2</sup>  
SUPERFICIE CONSTRUIDA TERRAZA..... 43.07 m<sup>2</sup>

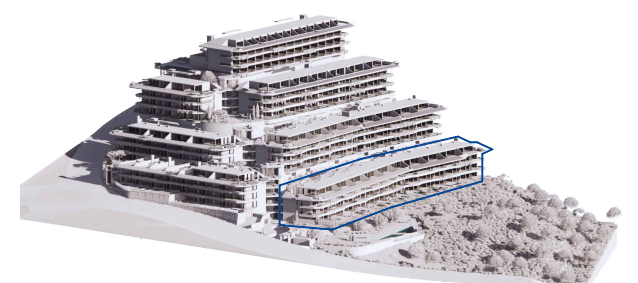

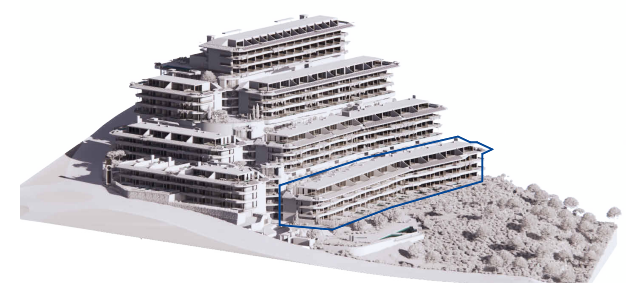
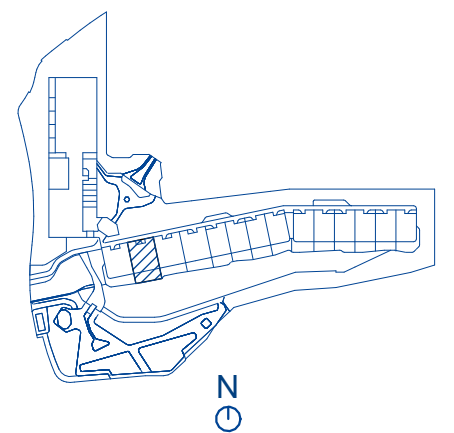
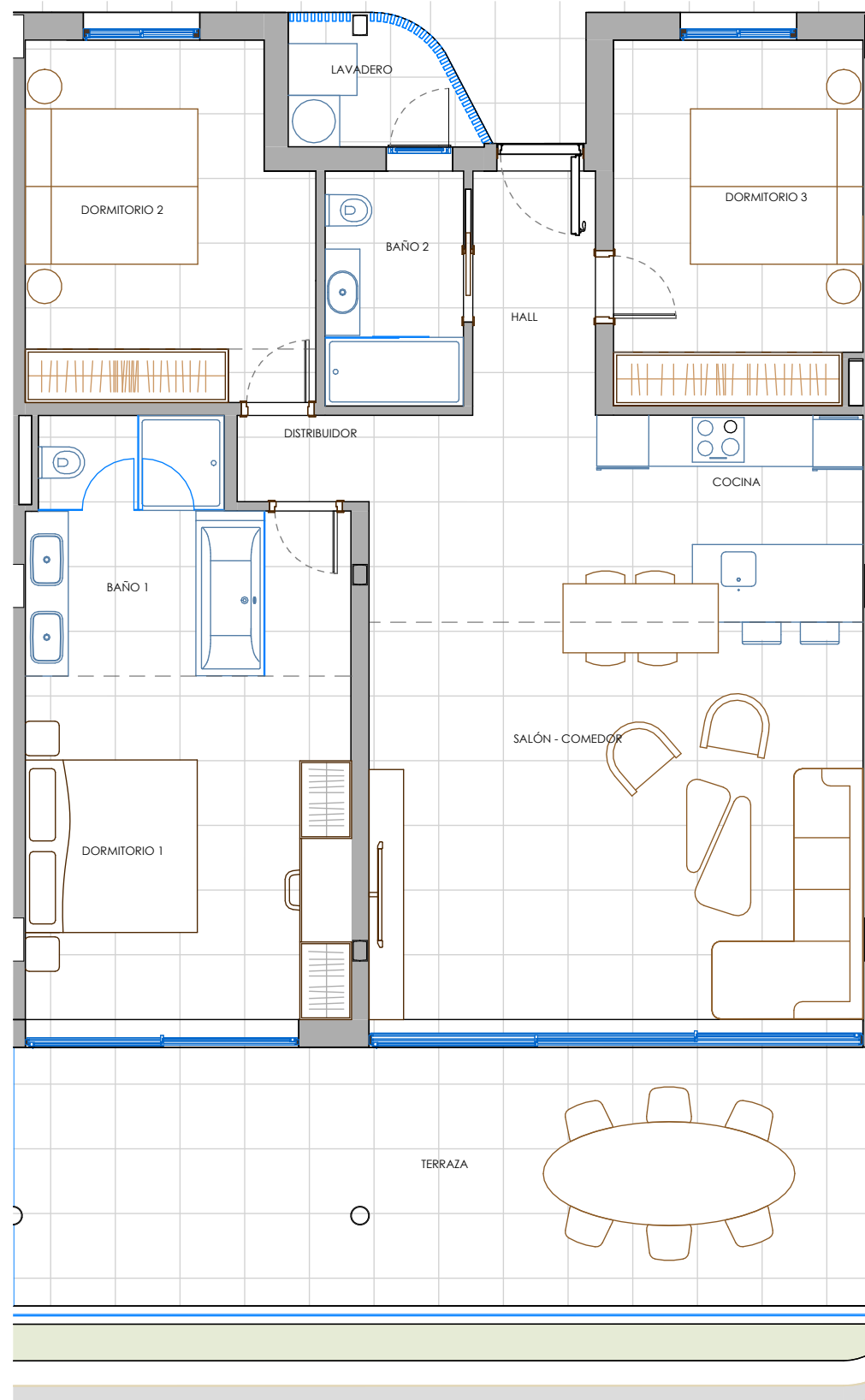

NIÁGARA (Módulo D2)  
P1 B  
Apartamento nº 197

SUPERFICIE CONSTRUIDA VIVIENDA..... 117.7 m<sup>2</sup>  
SUPERFICIE CONSTRUIDA TERRAZA..... 31.93 m<sup>2</sup>

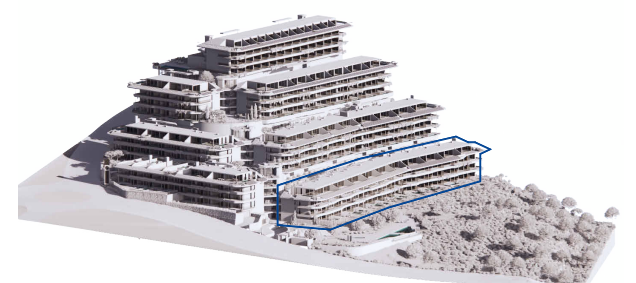
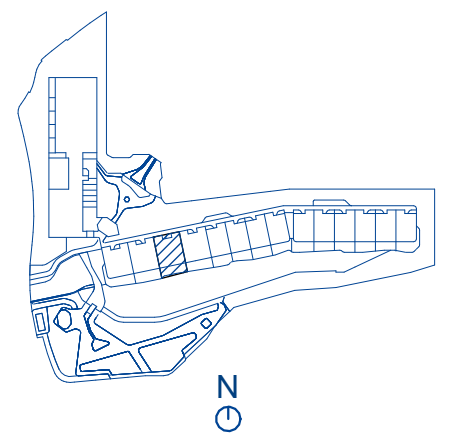
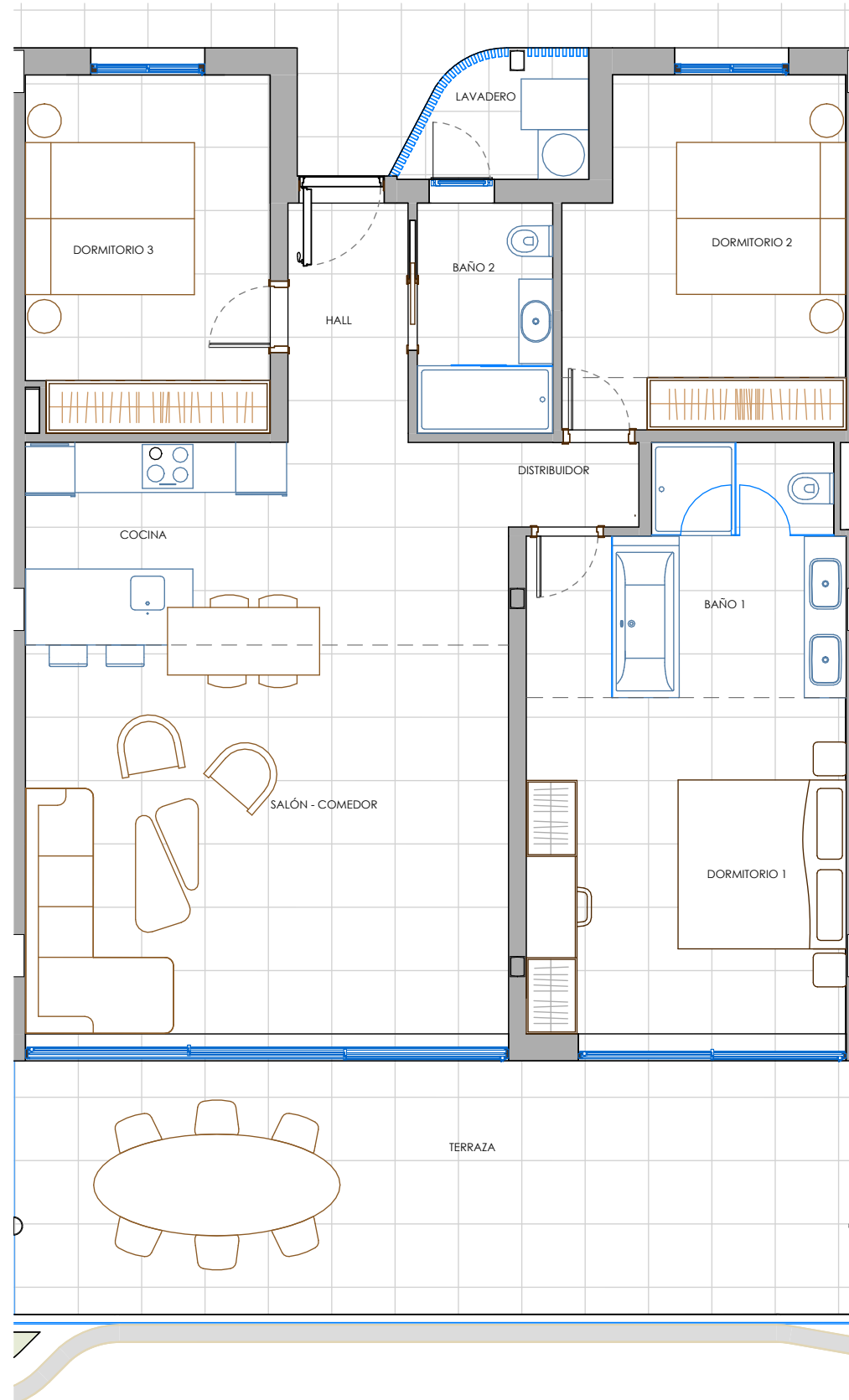

NIÁGARA (Módulo D2)  
P1 C  
Apartamento nº 198

SUPERFICIE CONSTRUIDA VIVIENDA..... 117.65 m<sup>2</sup>

SUPERFICIE CONSTRUIDA TERRAZA..... 33.06 m<sup>2</sup>

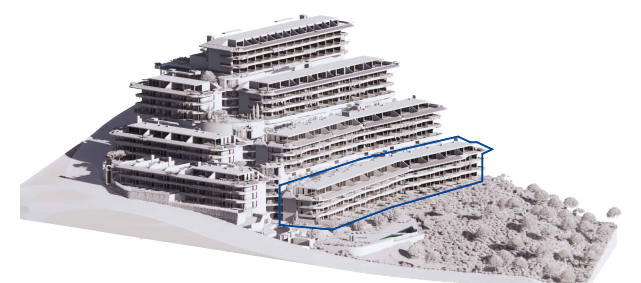
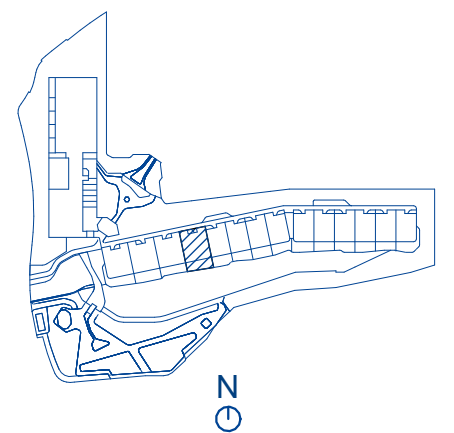
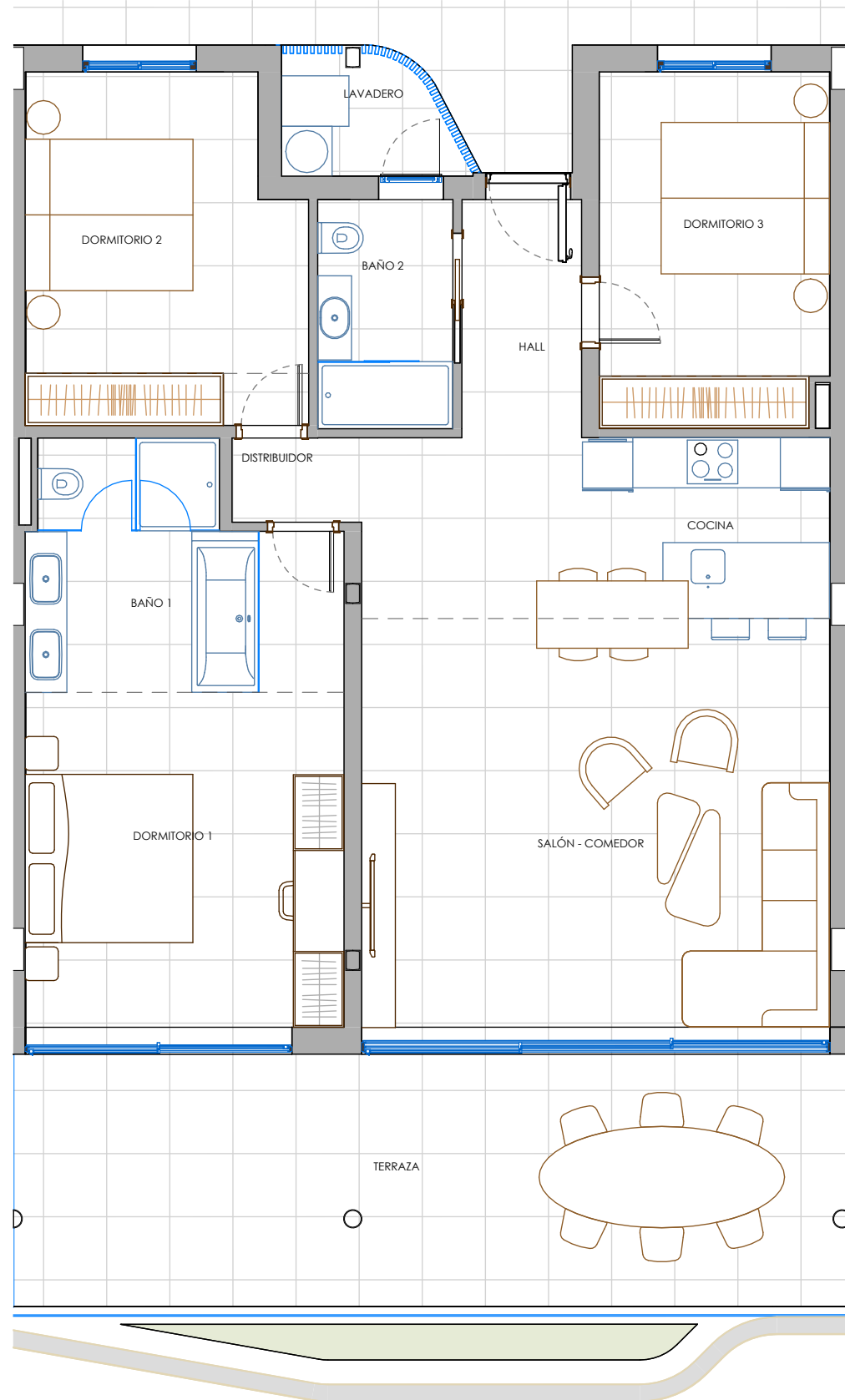

NIÁGARA (Módulo D2)  
P1 D  
Apartamento nº 199

SUPERFICIE CONSTRUIDA VIVIENDA..... 117.66 m<sup>2</sup>

SUPERFICIE CONSTRUIDA TERRAZA..... 32.16 m<sup>2</sup>

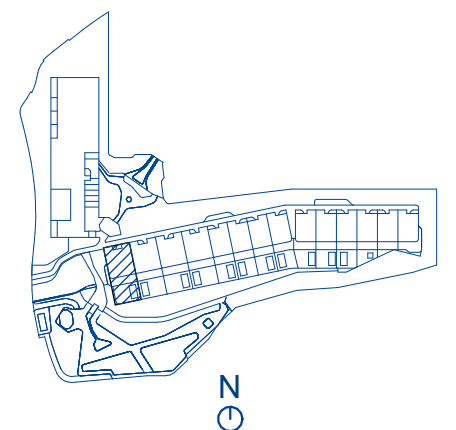
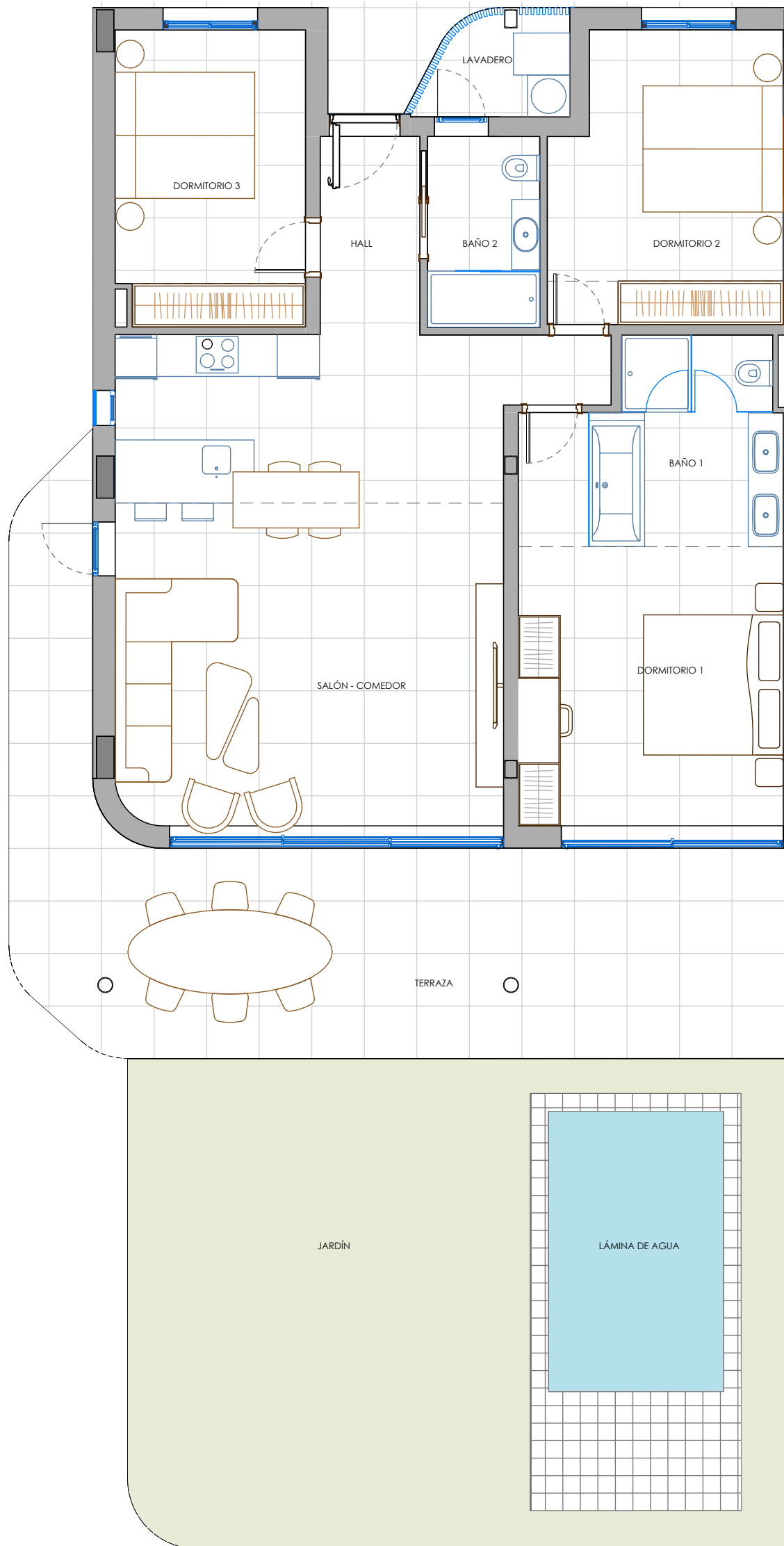

NIÁGARA (Módulo D2)  
Garden Villa A  
Apartamento nº 182

SUPERFICIE CONSTRUIDA VIVIENDA.....	117.33 m <sup>2</sup>
SUPERFICIE CONSTRUIDA TERRAZA.....	39.45 m <sup>2</sup>
SUPERFICIE JARDÍN.....	48.45 m <sup>2</sup>
SUPERFICIE LÁMINA & PLAYA PISCINA.....	17.85 m <sup>2</sup>
<b>SUPERFICIE EXTERIOR TOTAL</b>	<b>105.75 m<sup>2</sup></b>

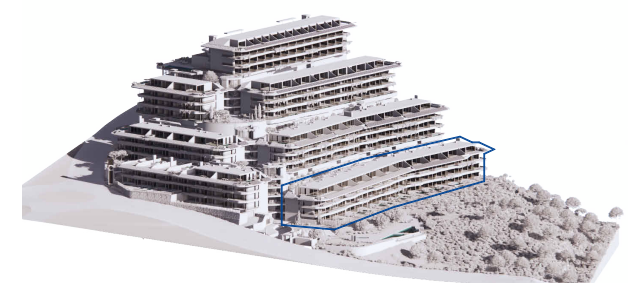



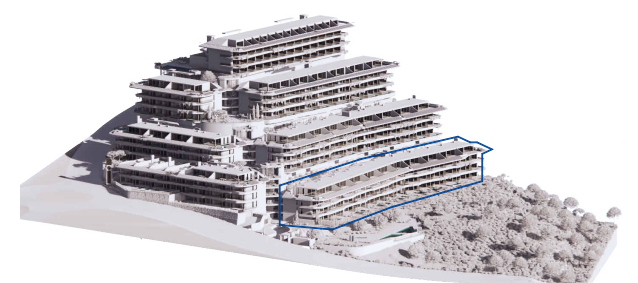
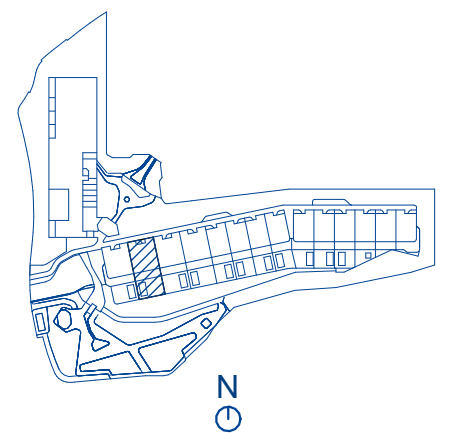
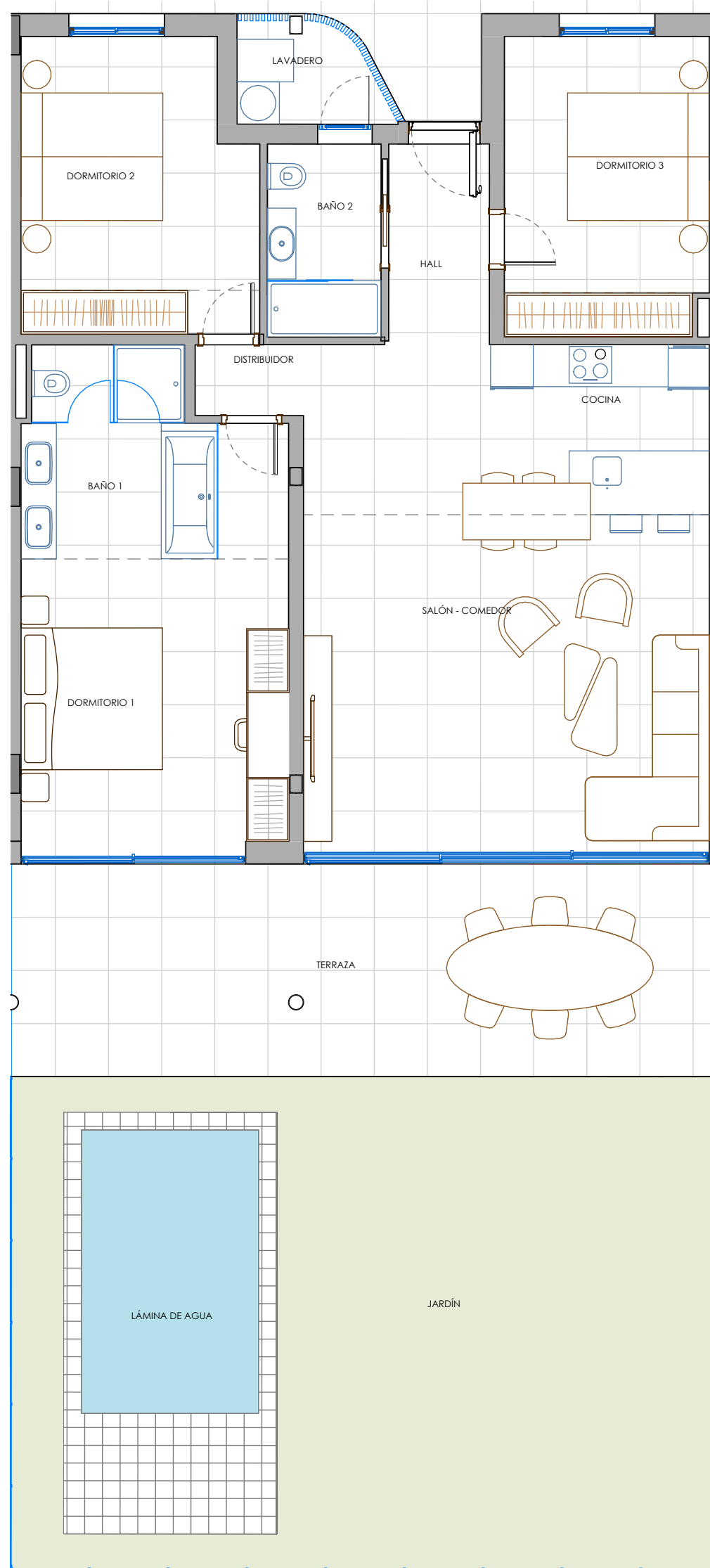

NIÁGARA (Módulo D2)  
Garden Villa B  
Apartamento nº 183

SUPERFICIE CONSTRUIDA VIVIENDA.....	117.70 m <sup>2</sup>
SUPERFICIE CONSTRUIDA TERRAZA.....	30.06 m <sup>2</sup>
SUPERFICIE JARDÍN.....	52.19 m <sup>2</sup>
SUPERFICIE LÁMINA & PLAYA PISCINA.....	17.85 m <sup>2</sup>
<b>SUPERFICIE EXTERIOR TOTAL</b>	<b>100.10 m<sup>2</sup></b>

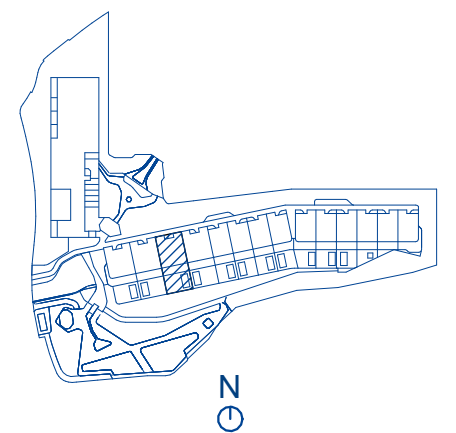
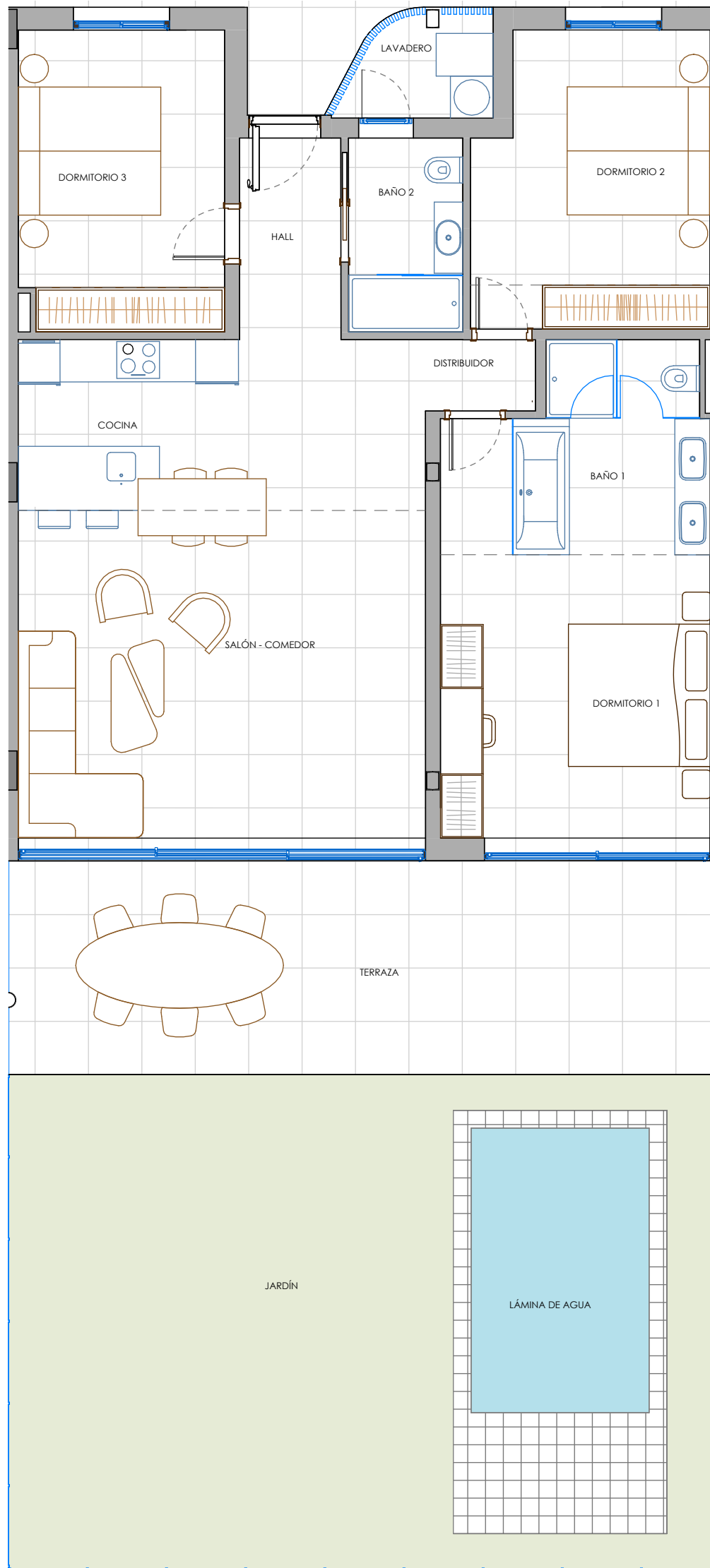

NIÁGARA (Módulo D2)  
Garden Villa C  
Apartamento nº 184

SUPERFICIE CONSTRUIDA VIVIENDA.....	117.65 m <sup>2</sup>
SUPERFICIE CONSTRUIDA TERRAZA.....	30.07 m <sup>2</sup>
SUPERFICIE JARDÍN.....	52.18 m <sup>2</sup>
SUPERFICIE LÁMINA & PLAYA PISCINA.....	17.85 m <sup>2</sup>
<b>SUPERFICIE EXTERIOR TOTAL</b>	<b>100.10 m<sup>2</sup></b>

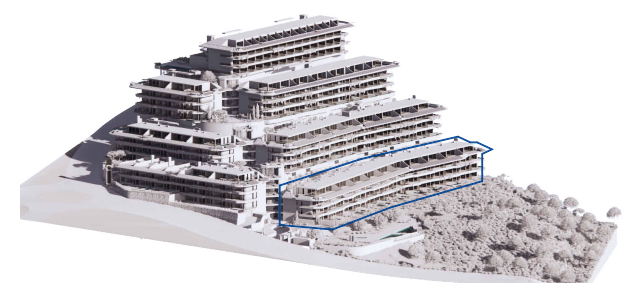

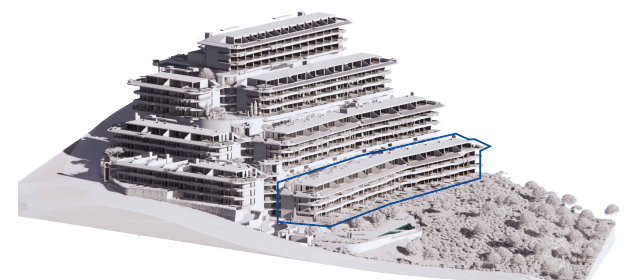
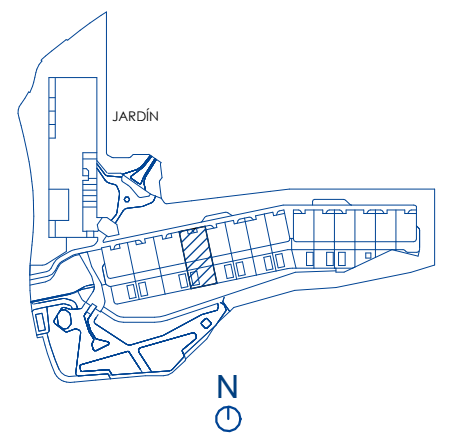
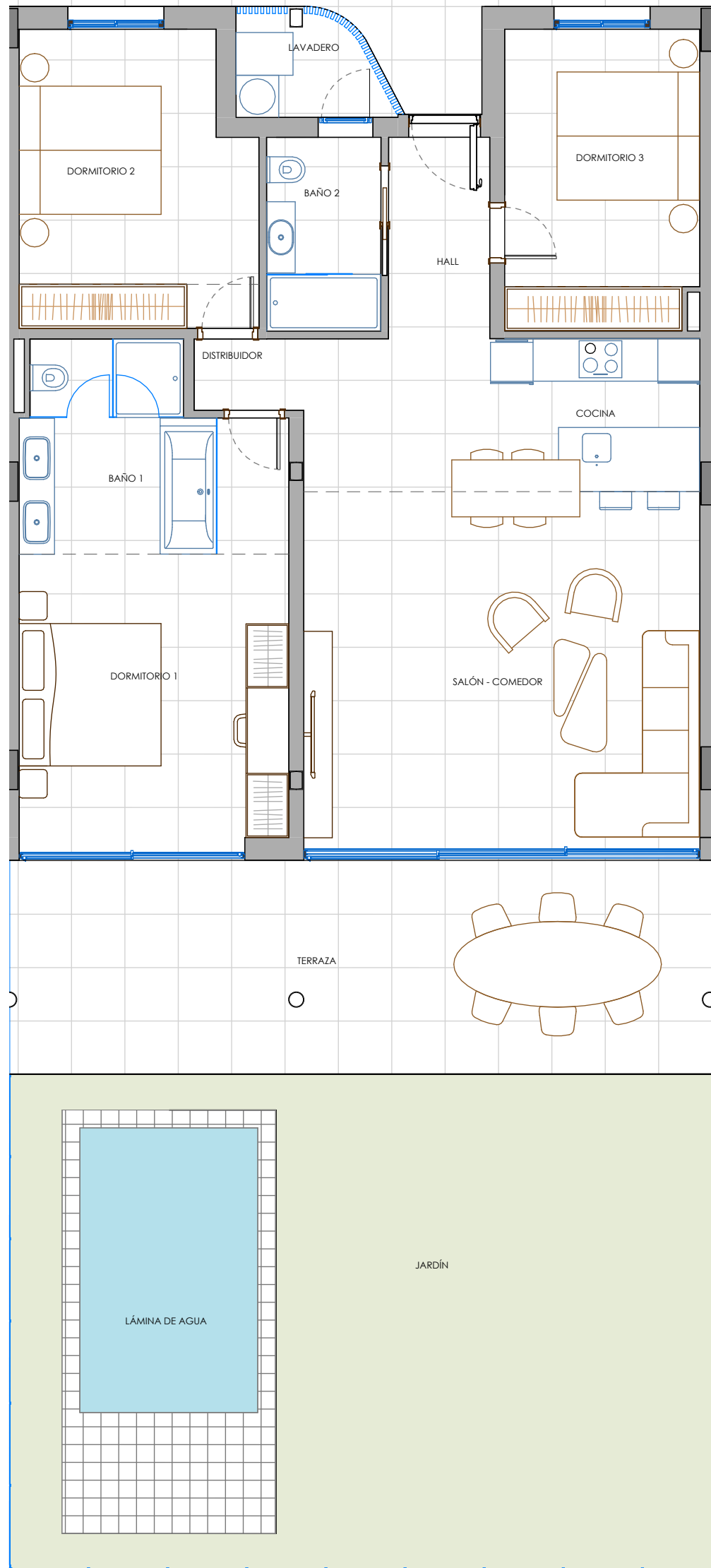

NIÁGARA (Módulo D2)  
Garden Villa D  
Apartamento nº 185

SUPERFICIE CONSTRUIDA VIVIENDA.....	117.66 m <sup>2</sup>
SUPERFICIE CONSTRUIDA TERRAZA.....	30.11 m <sup>2</sup>
SUPERFICIE JARDÍN.....	52.20 m <sup>2</sup>
SUPERFICIE LÁMINA & PLAYA PISCINA.....	17.85 m <sup>2</sup>
<b>SUPERFICIE EXTERIOR TOTAL</b>	<b>106.16 m<sup>2</sup></b>

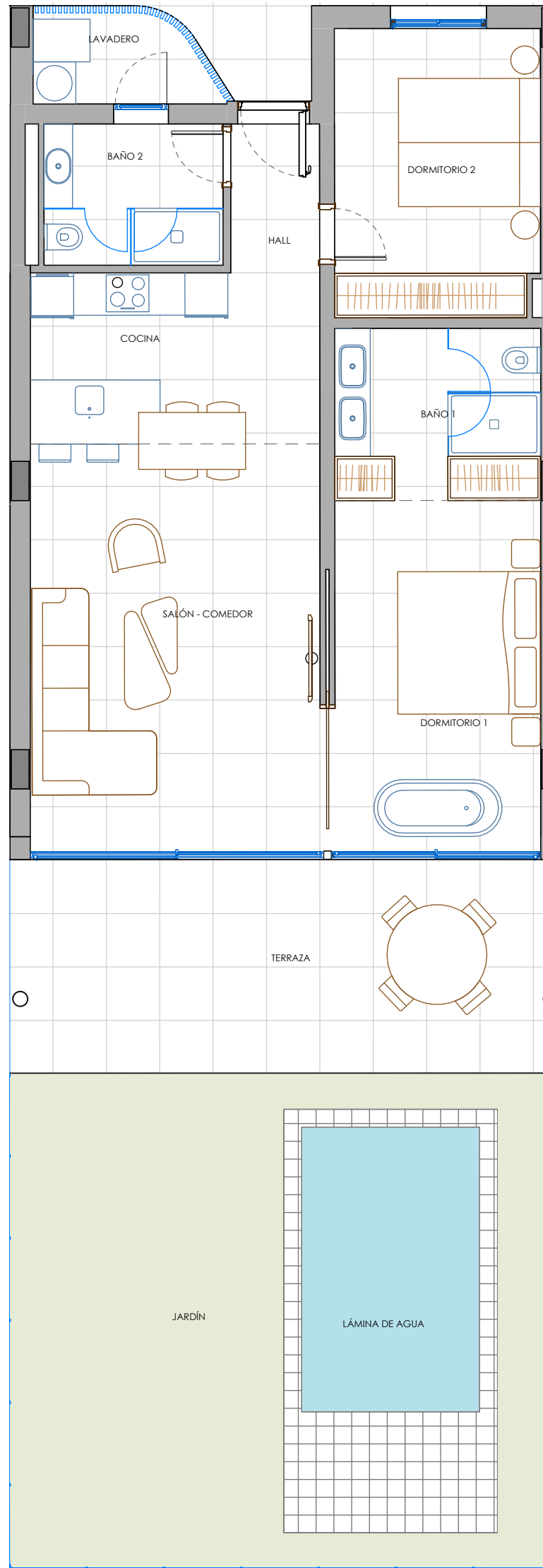

NIÁGARA (Módulo D2)  
Garden Villa E  
Apartamento nº 186

SUPERFICIE CONSTRUIDA VIVIENDA.....	89.15 m <sup>2</sup>
SUPERFICIE CONSTRUIDA TERRAZA.....	22.92 m <sup>2</sup>
SUPERFICIE JARDÍN.....	35.41 m <sup>2</sup>
SUPERFICIE LÁMINA & PLAYA PISCINA.....	17.85 m <sup>2</sup>
<b>SUPERFICIE EXTERIOR TOTAL</b>	<b>76.18 m<sup>2</sup></b>

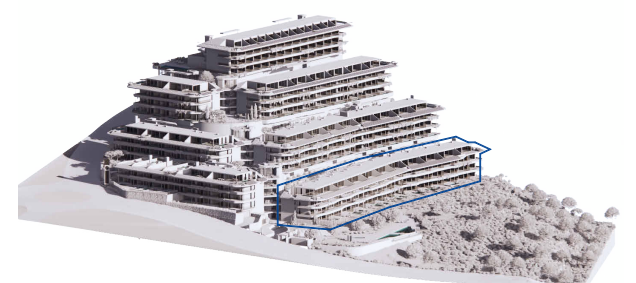
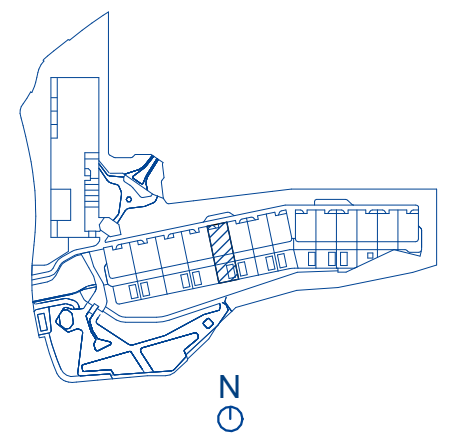

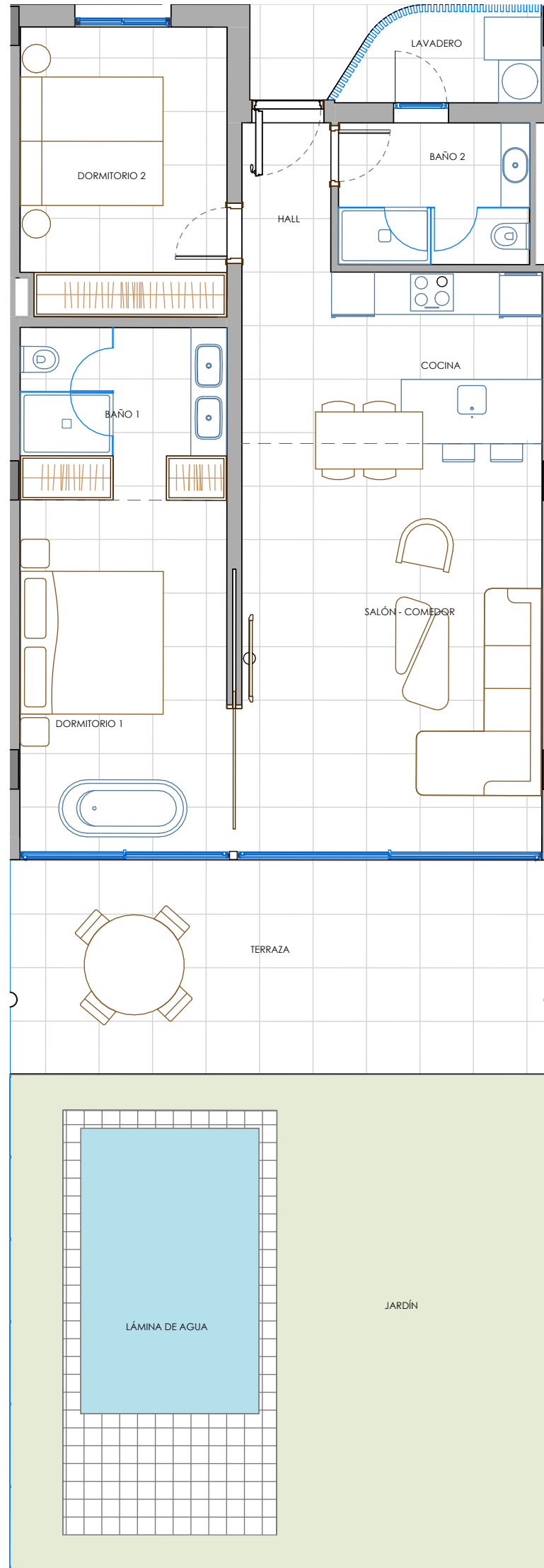

NIÁGARA (Módulo D2)  
Garden Villa F  
Apartamento nº 187

SUPERFICIE CONSTRUIDA VIVIENDA.....	89.14 m <sup>2</sup>
SUPERFICIE CONSTRUIDA TERRAZA.....	22.93 m <sup>2</sup>
SUPERFICIE JARDÍN.....	35.42 m <sup>2</sup>
SUPERFICIE LÁMINA & PLAYA PISCINA.....	17.85 m <sup>2</sup>
<b>SUPERFICIE EXTERIOR TOTAL</b>	<b>76.20 m<sup>2</sup></b>

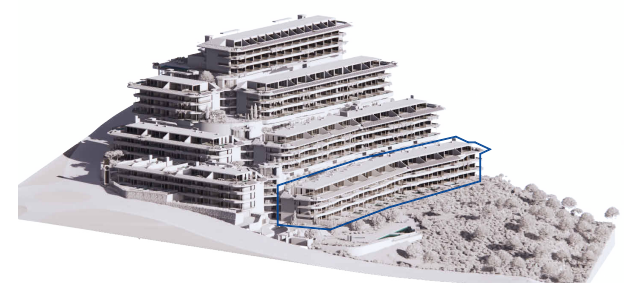
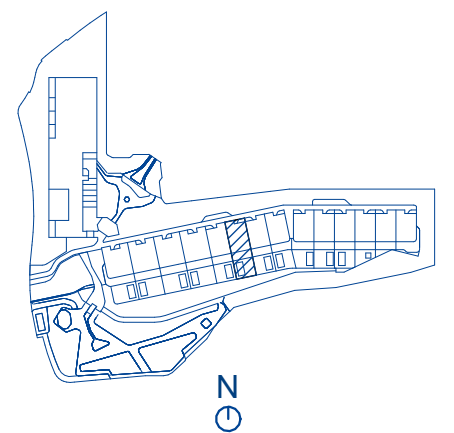

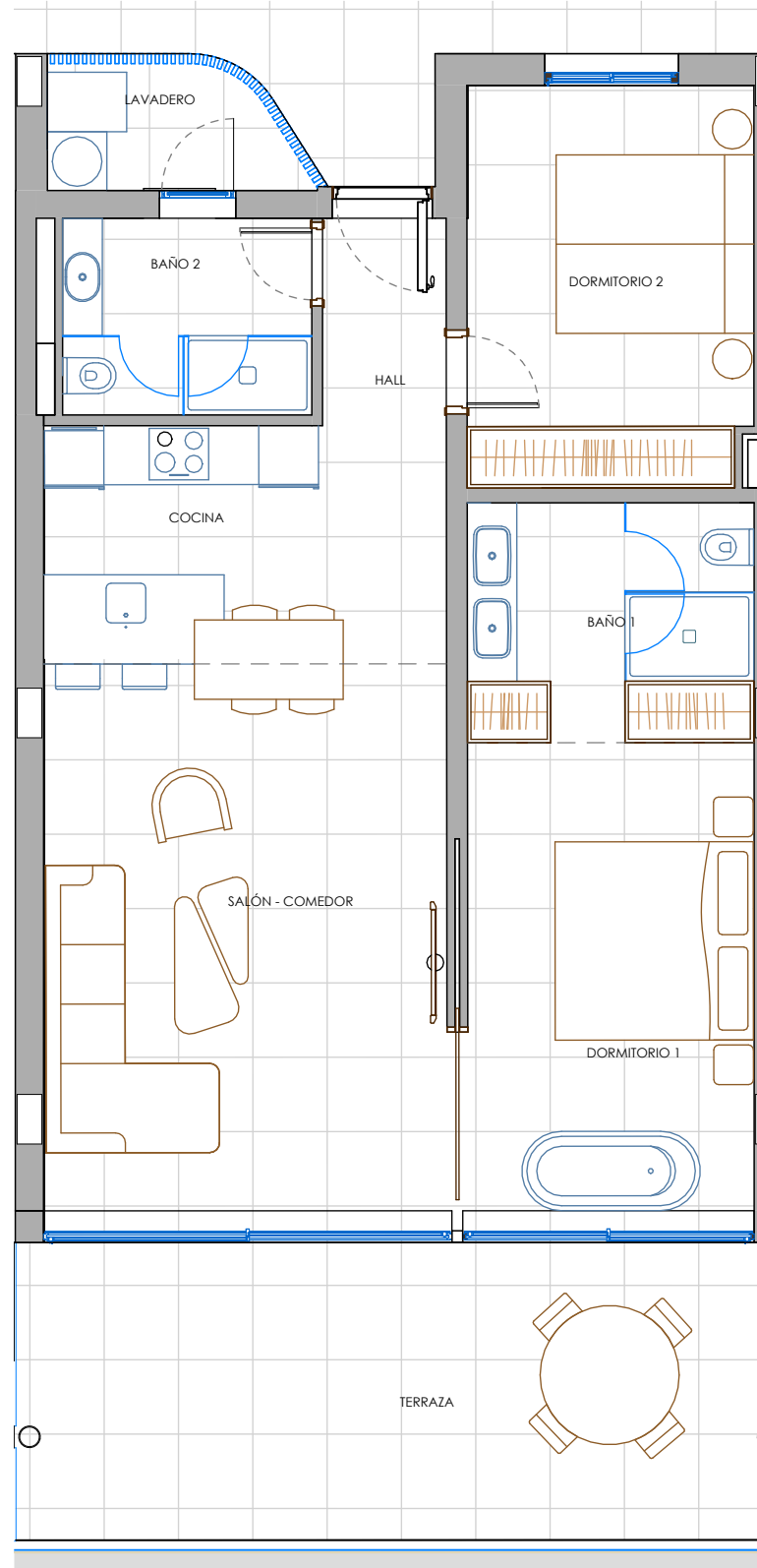

NIÁGARA (Módulo D2)  
P1 E  
Apartamento nº 200

SUPERFICIE CONSTRUIDA VIVIENDA..... 89.15 m<sup>2</sup>  
SUPERFICIE CONSTRUIDA TERRAZA..... 25.30 m<sup>2</sup>

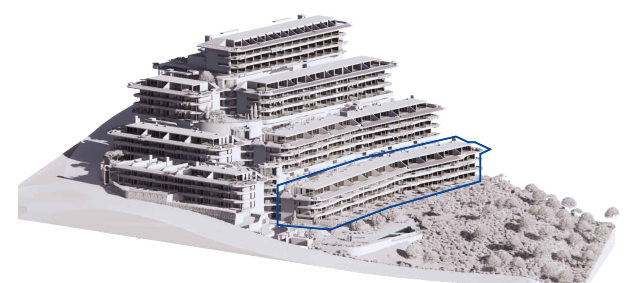
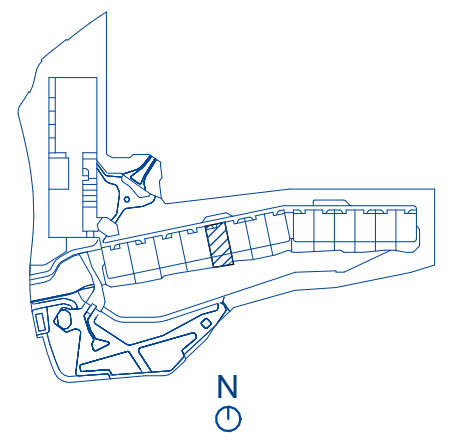

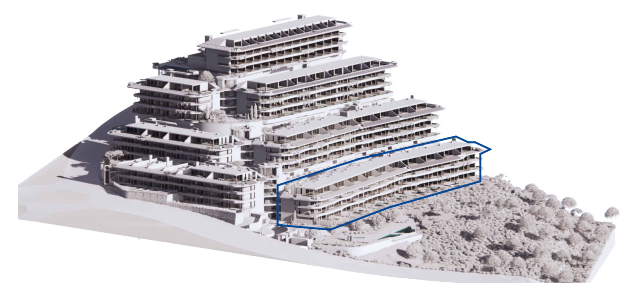
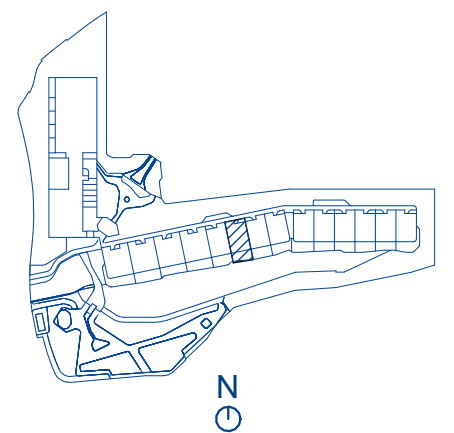
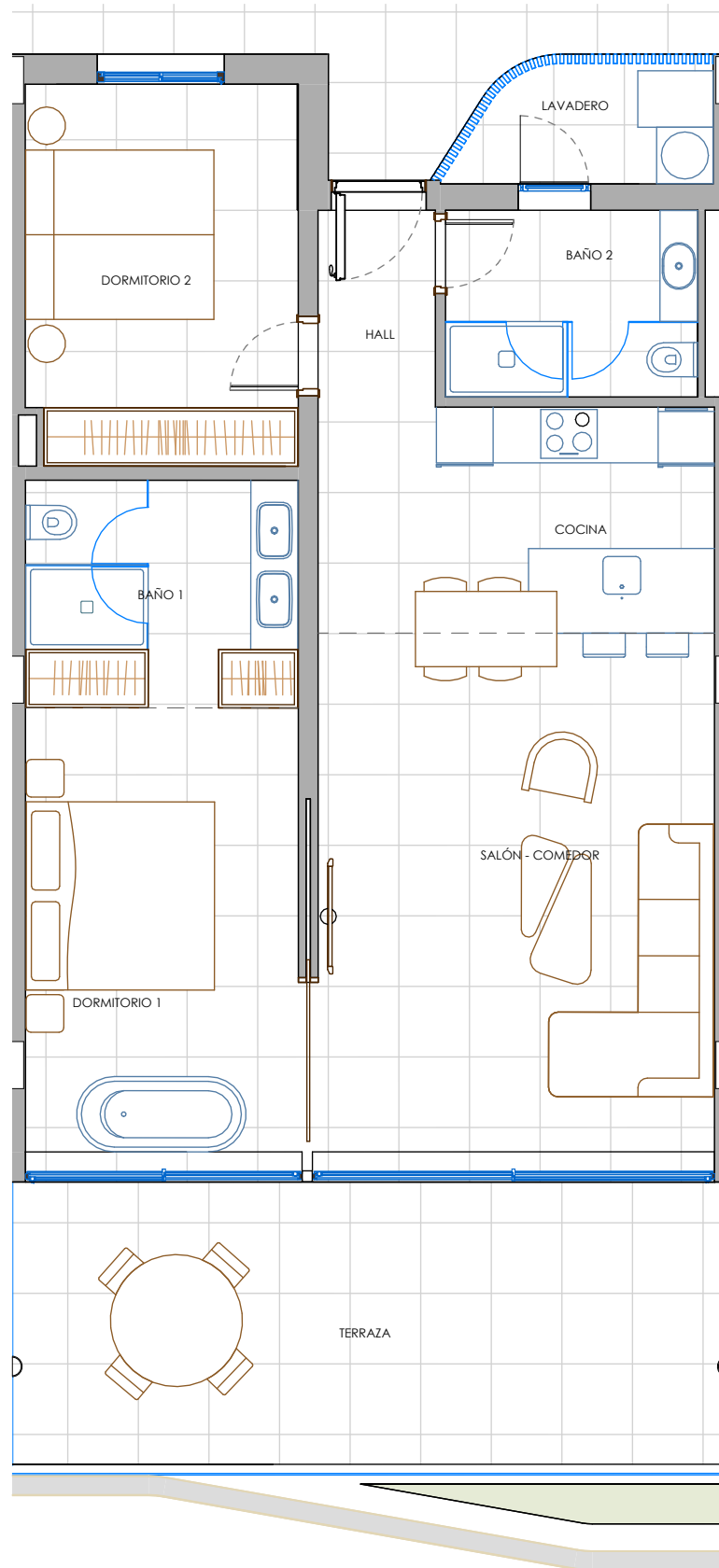

NIÁGARA (Módulo D2)  
P1 F  
Apartamento nº 201

SUPERFICIE CONSTRUIDA VIVIENDA..... 89.14 m<sup>2</sup>  
SUPERFICIE CONSTRUIDA TERRAZA..... 24.57 m<sup>2</sup>



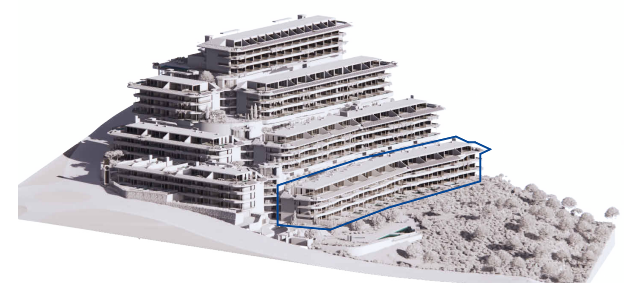
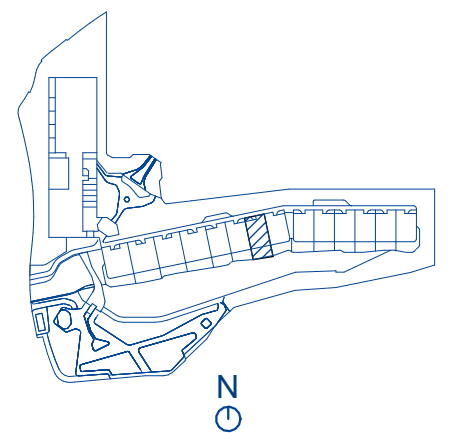
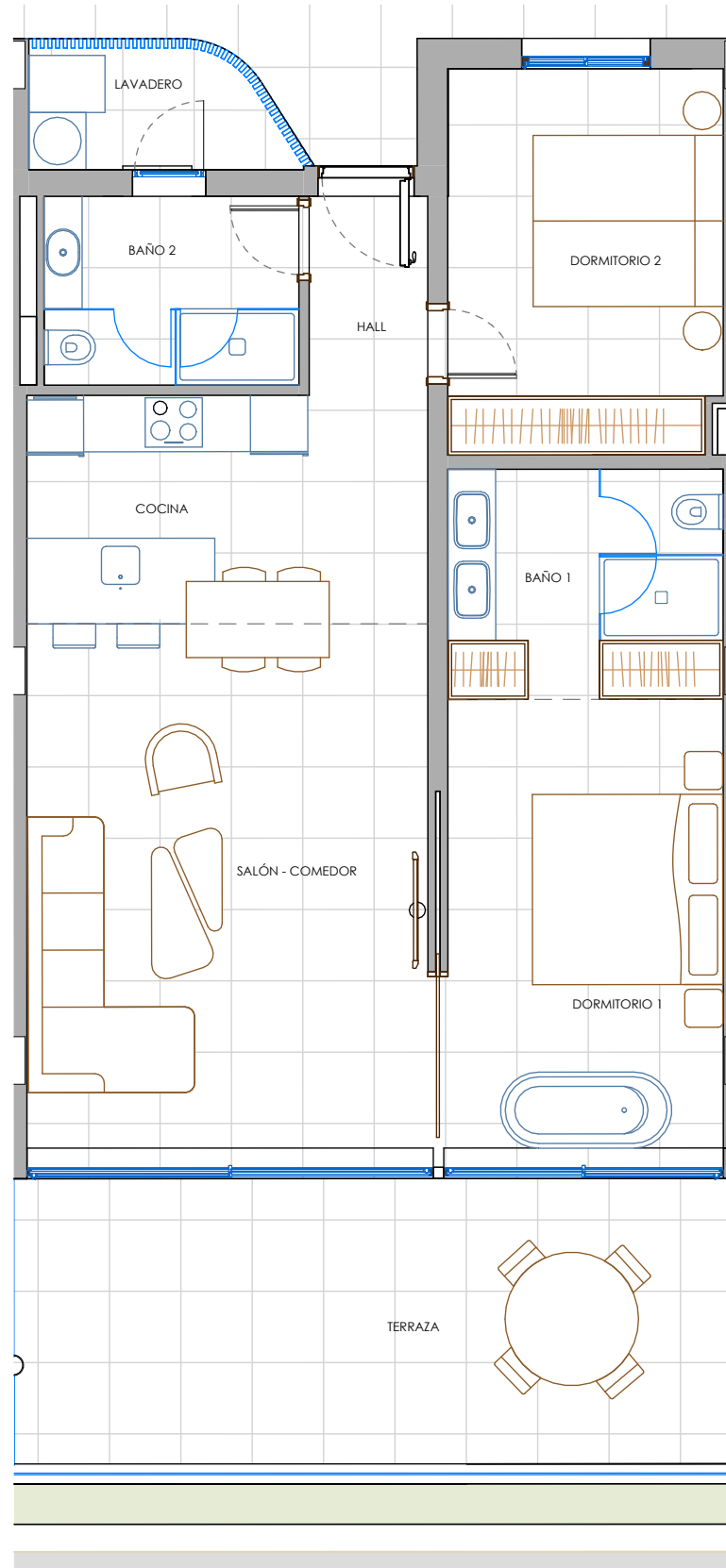

NIÁGARA (Módulo D2)  
P1 G  
Apartamento nº 202

SUPERFICIE CONSTRUIDA VIVIENDA..... 89.03 m<sup>2</sup>  
SUPERFICIE CONSTRUIDA TERRAZA..... 24.46 m<sup>2</sup>

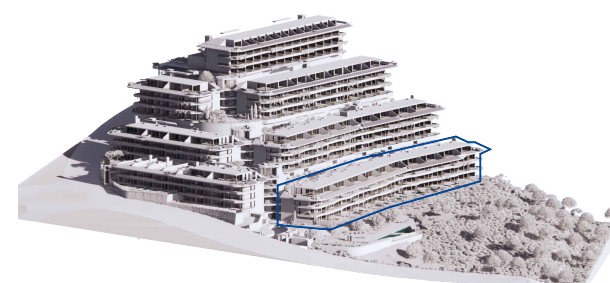
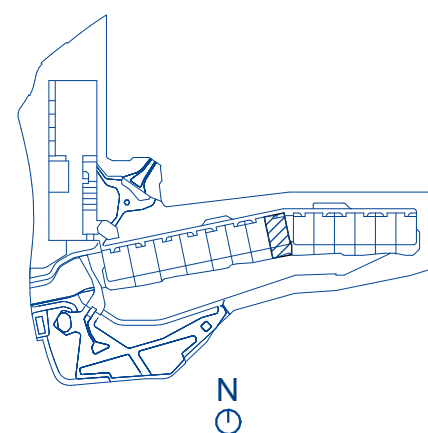
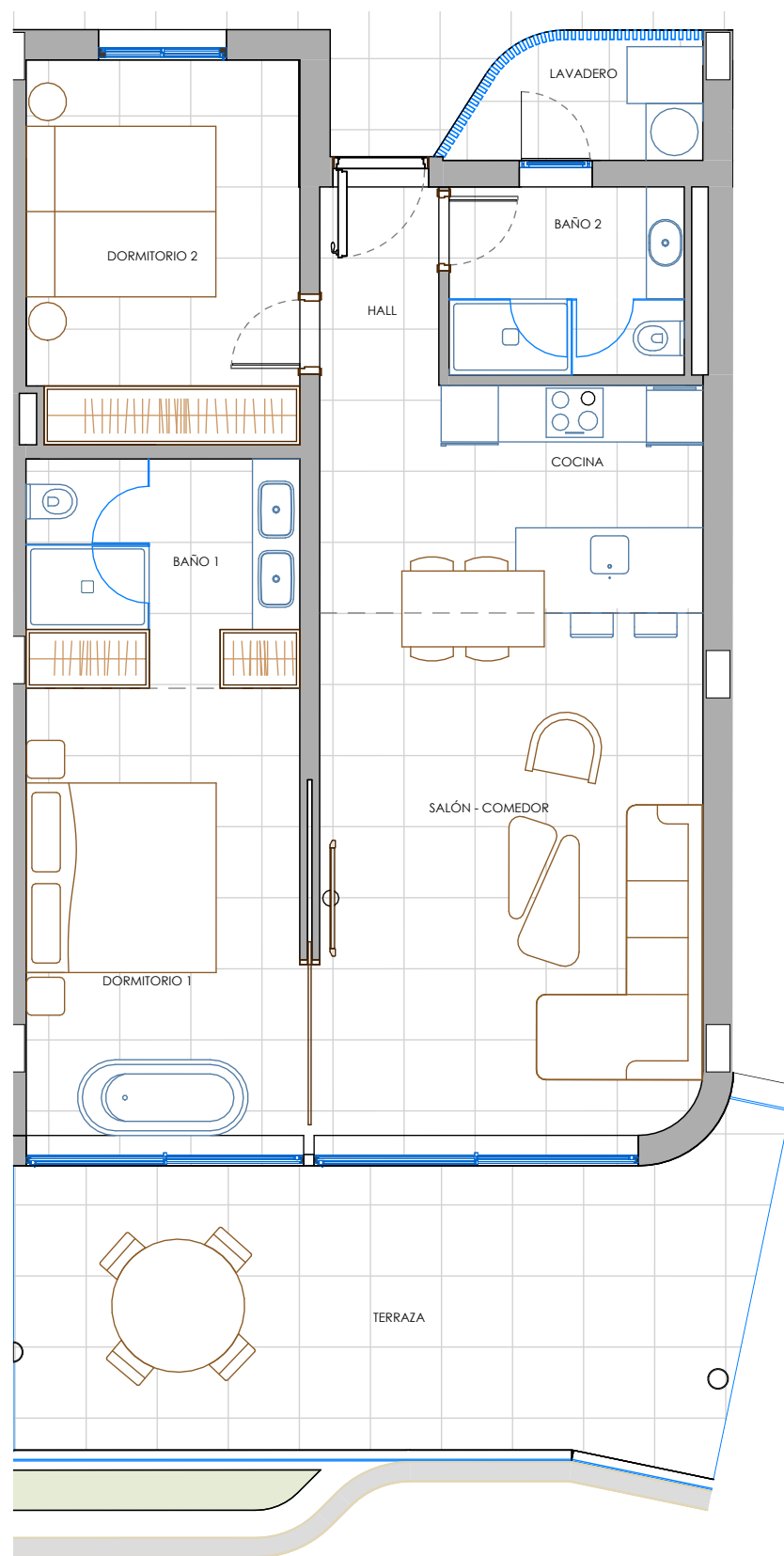

NIÁGARA (Módulo D2)  
P1 H  
Apartamento nº 203

SUPERFICIE CONSTRUIDA VIVIENDA..... 88.84 m<sup>2</sup>  
SUPERFICIE CONSTRUIDA TERRAZA..... 26.19 m<sup>2</sup>

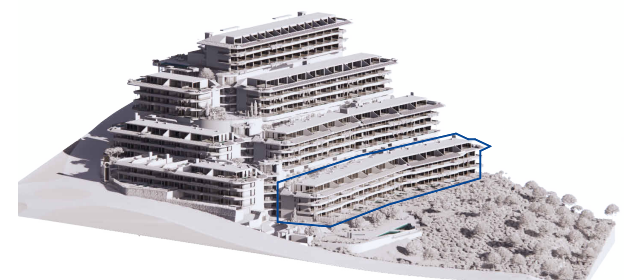
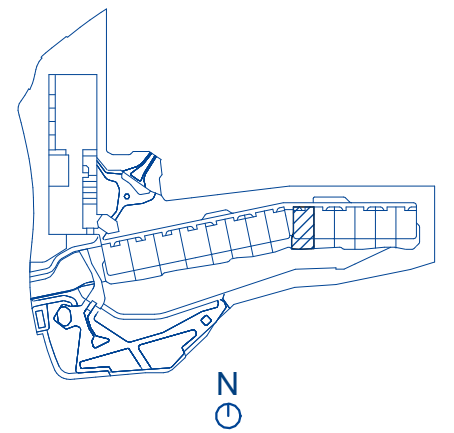
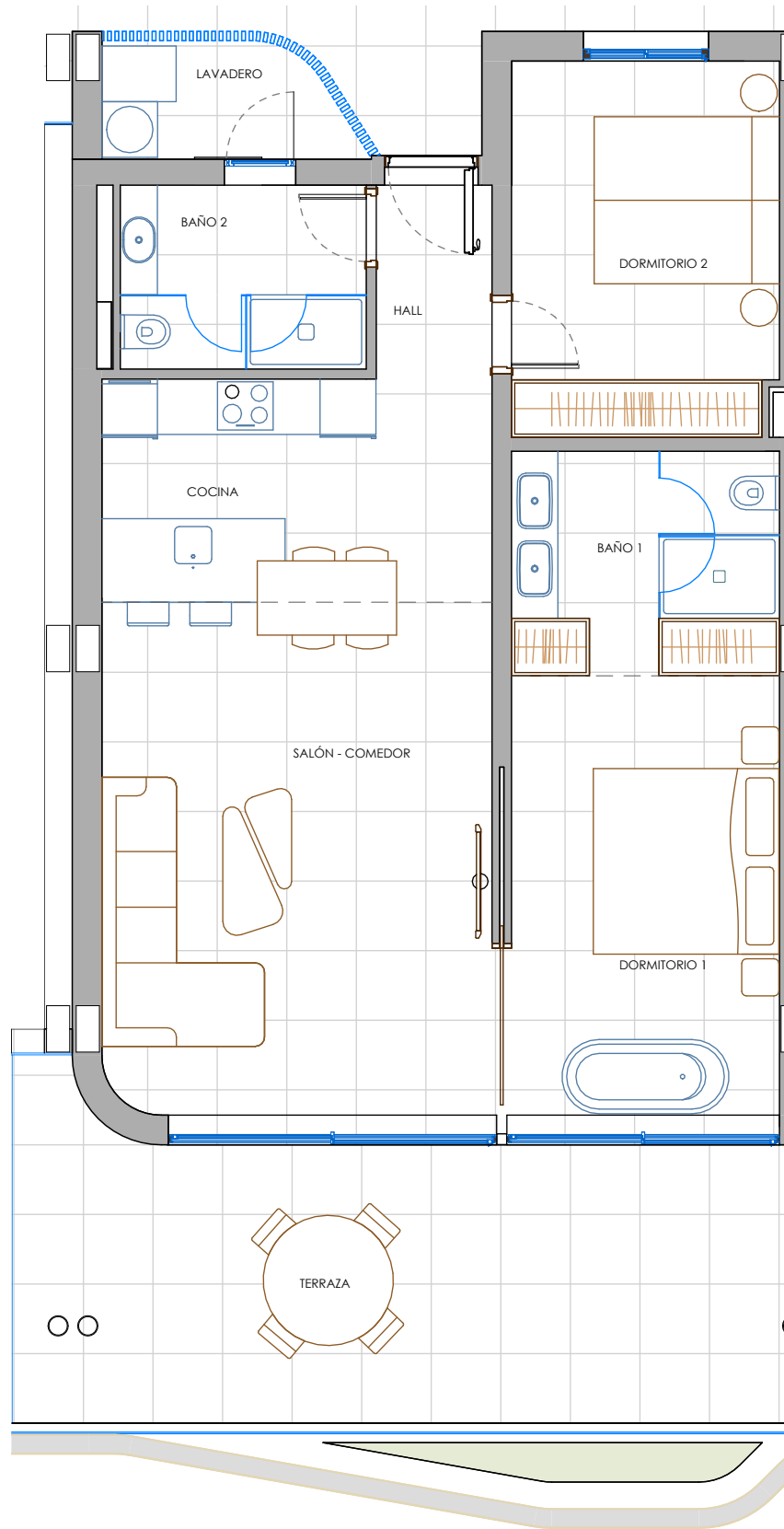

NIÁGARA (Módulo D2)  
P1 I  
Apartamento nº 204

SUPERFICIE CONSTRUIDA VIVIENDA..... 90.94 m<sup>2</sup>  
SUPERFICIE CONSTRUIDA TERRAZA..... 28.21 m<sup>2</sup>

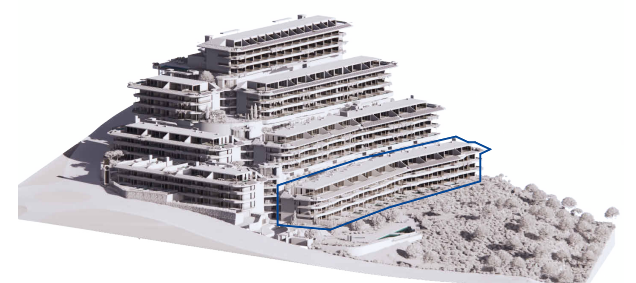
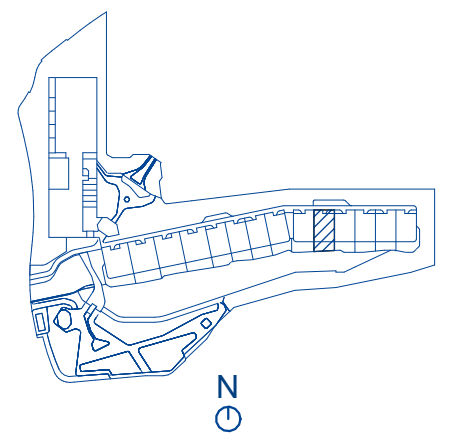
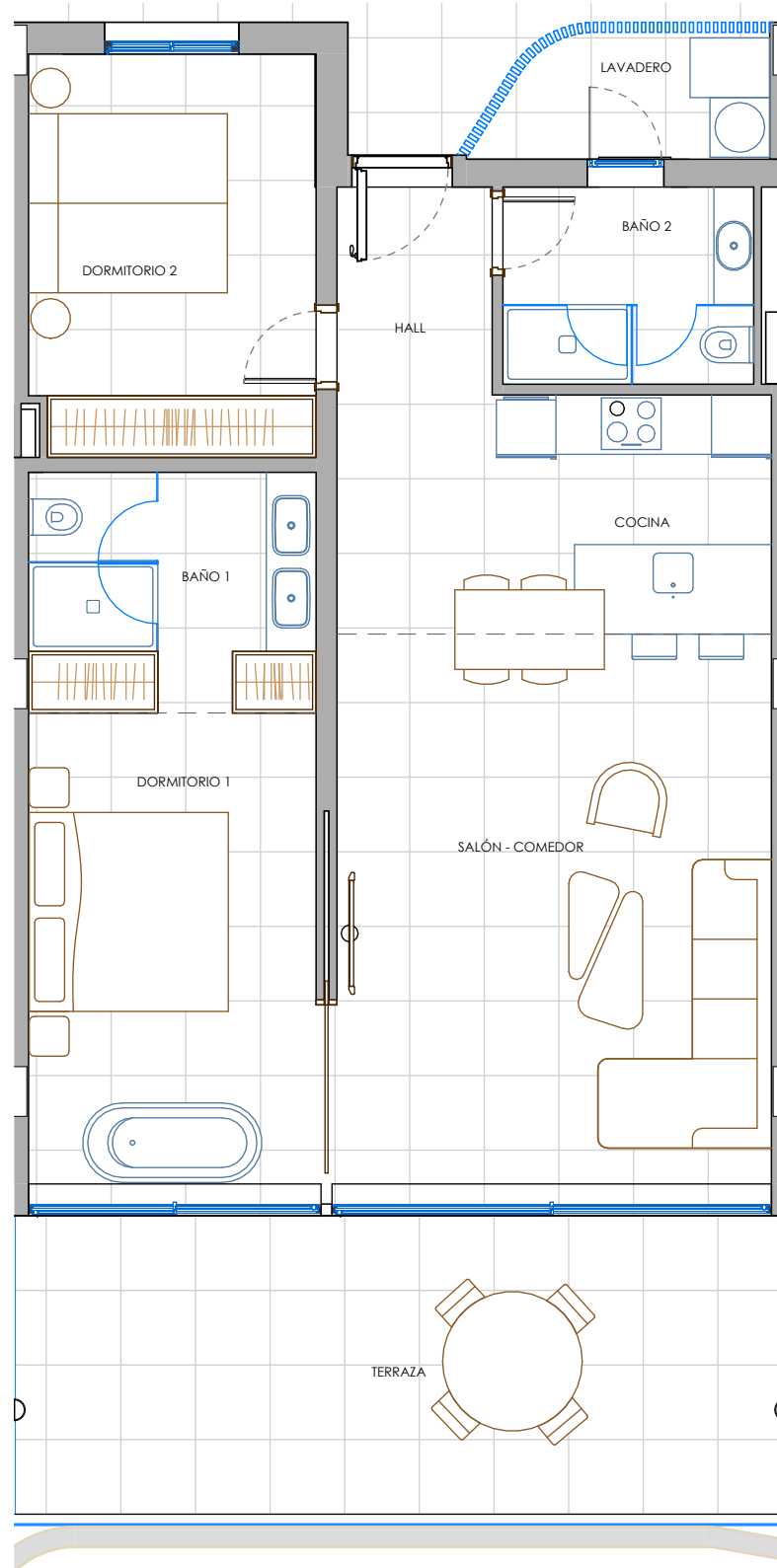

NIÁGARA (Módulo D2)  
P1 J  
Apartamento nº 205

SUPERFICIE CONSTRUIDA VIVIENDA..... 90.89 m<sup>2</sup>  
SUPERFICIE CONSTRUIDA TERRAZA..... 25.65 m<sup>2</sup>

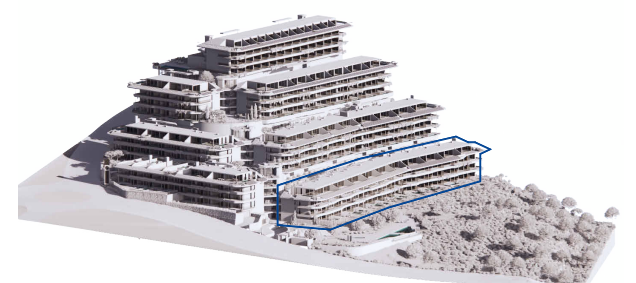
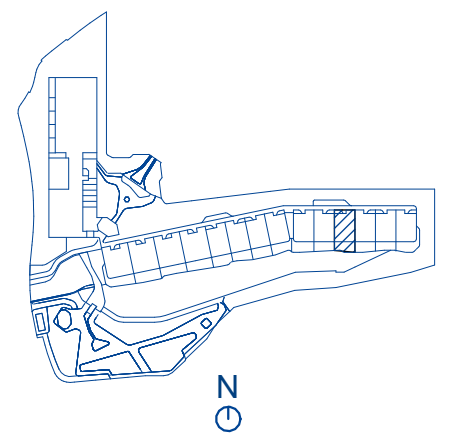
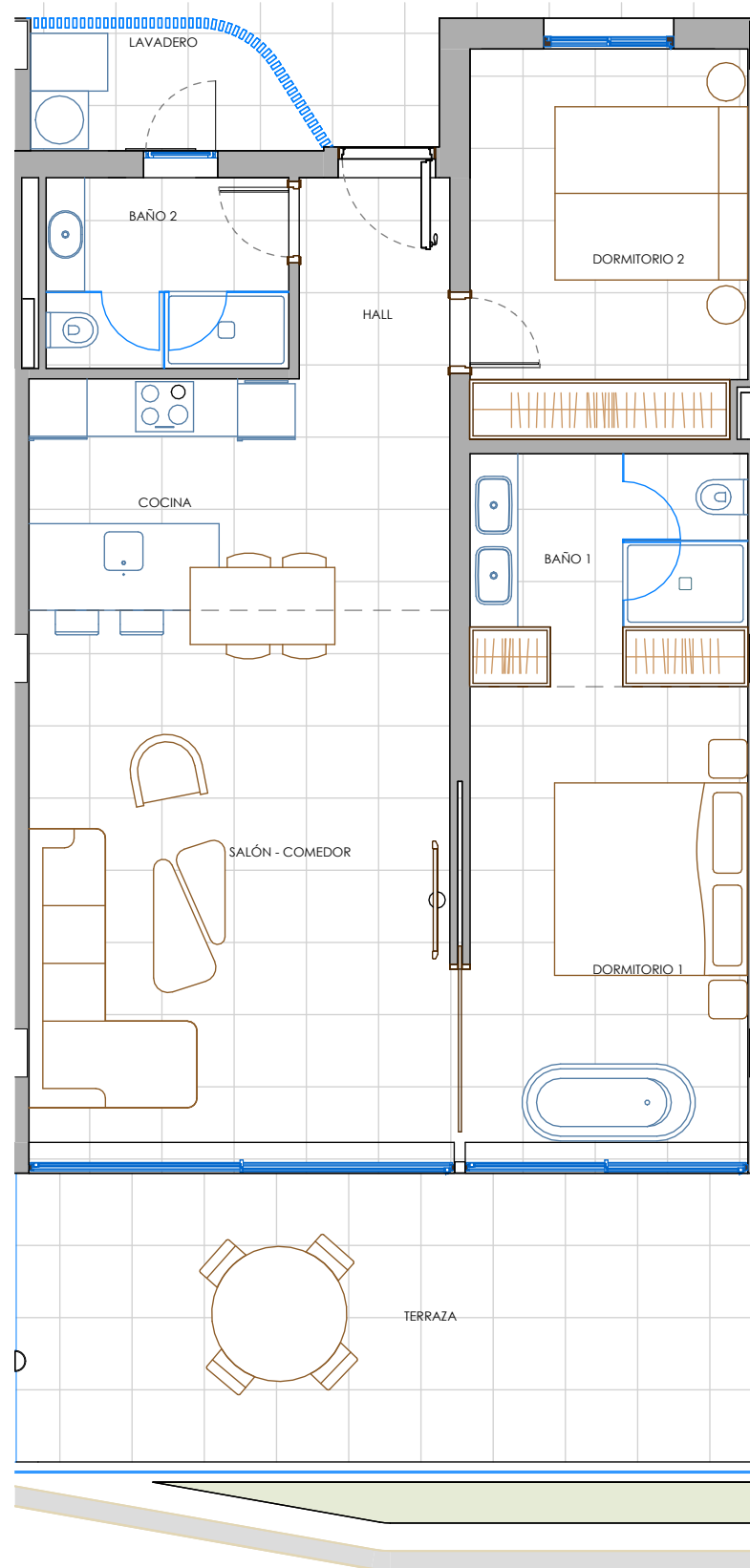

NIÁGARA (Módulo D2)  
P1 K  
Apartamento nº 206

SUPERFICIE CONSTRUIDA VIVIENDA..... 90.97 m<sup>2</sup>  
SUPERFICIE CONSTRUIDA TERRAZA..... 24.89 m<sup>2</sup>

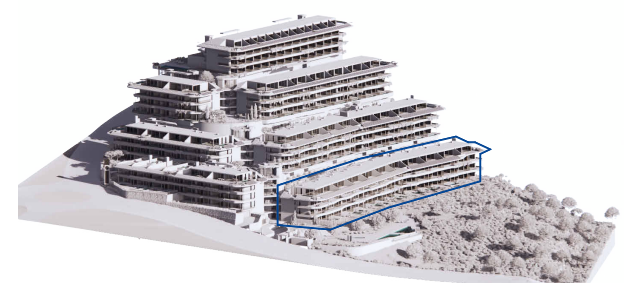
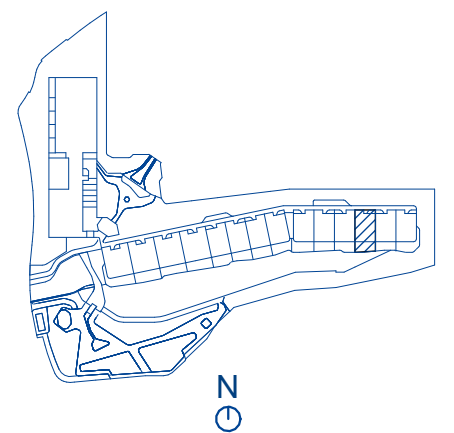
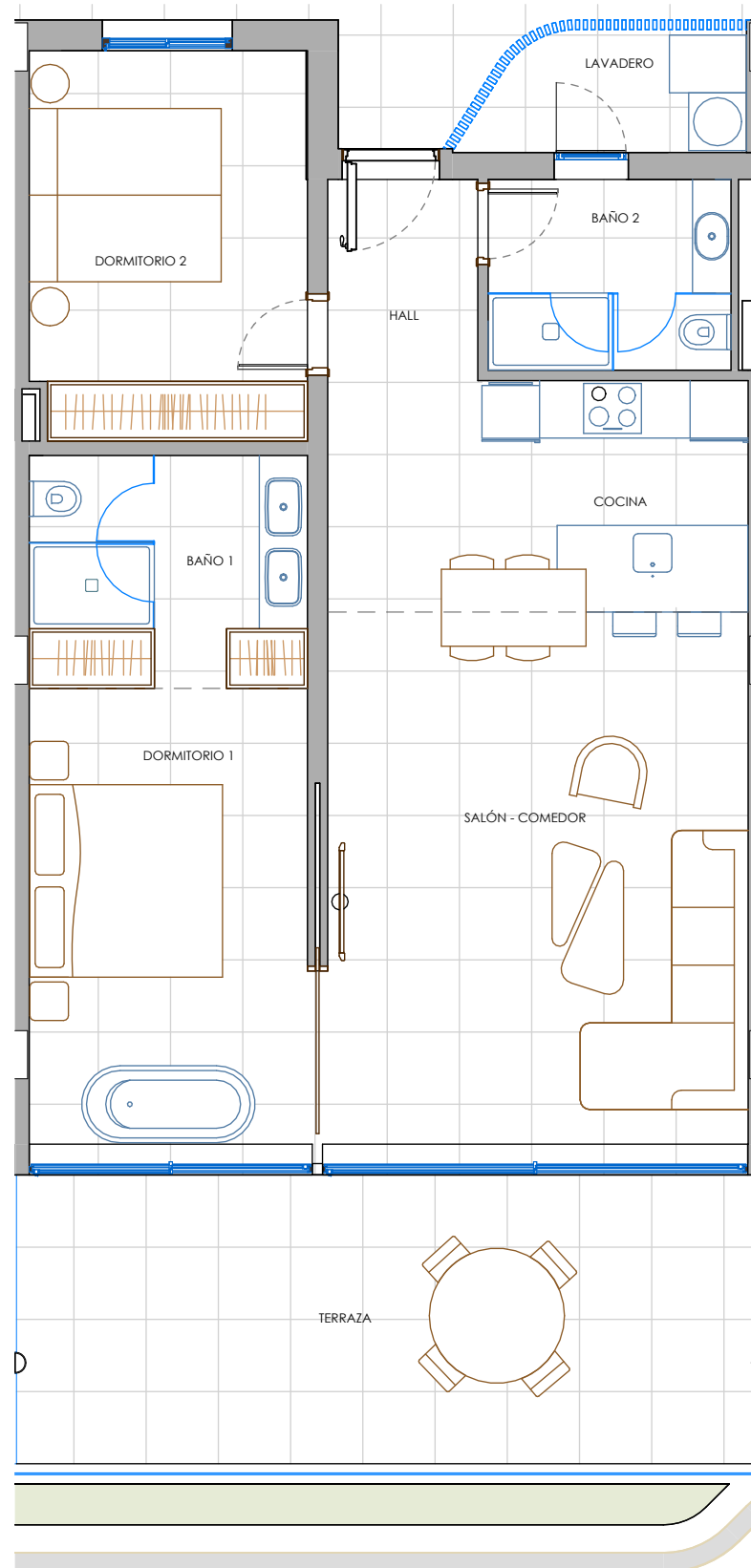

NIÁGARA (Módulo D2)  
P1 L  
Apartamento nº 207

SUPERFICIE CONSTRUIDA VIVIENDA..... 90.87 m<sup>2</sup>  
SUPERFICIE CONSTRUIDA TERRAZA..... 24.92 m<sup>2</sup>

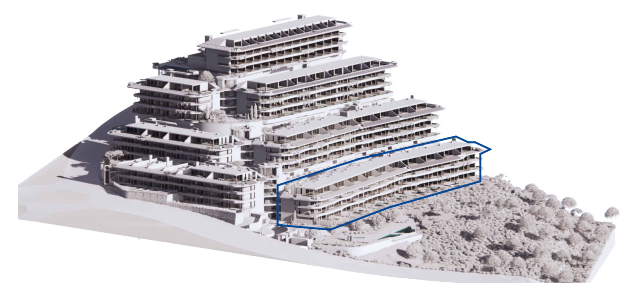
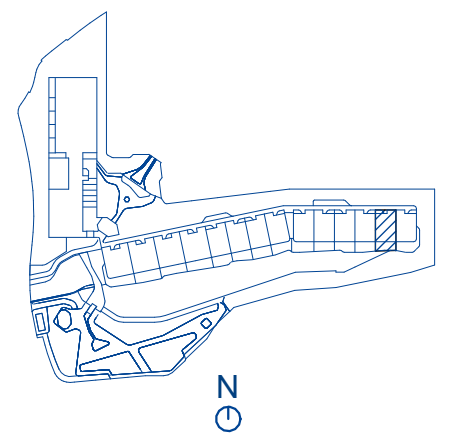
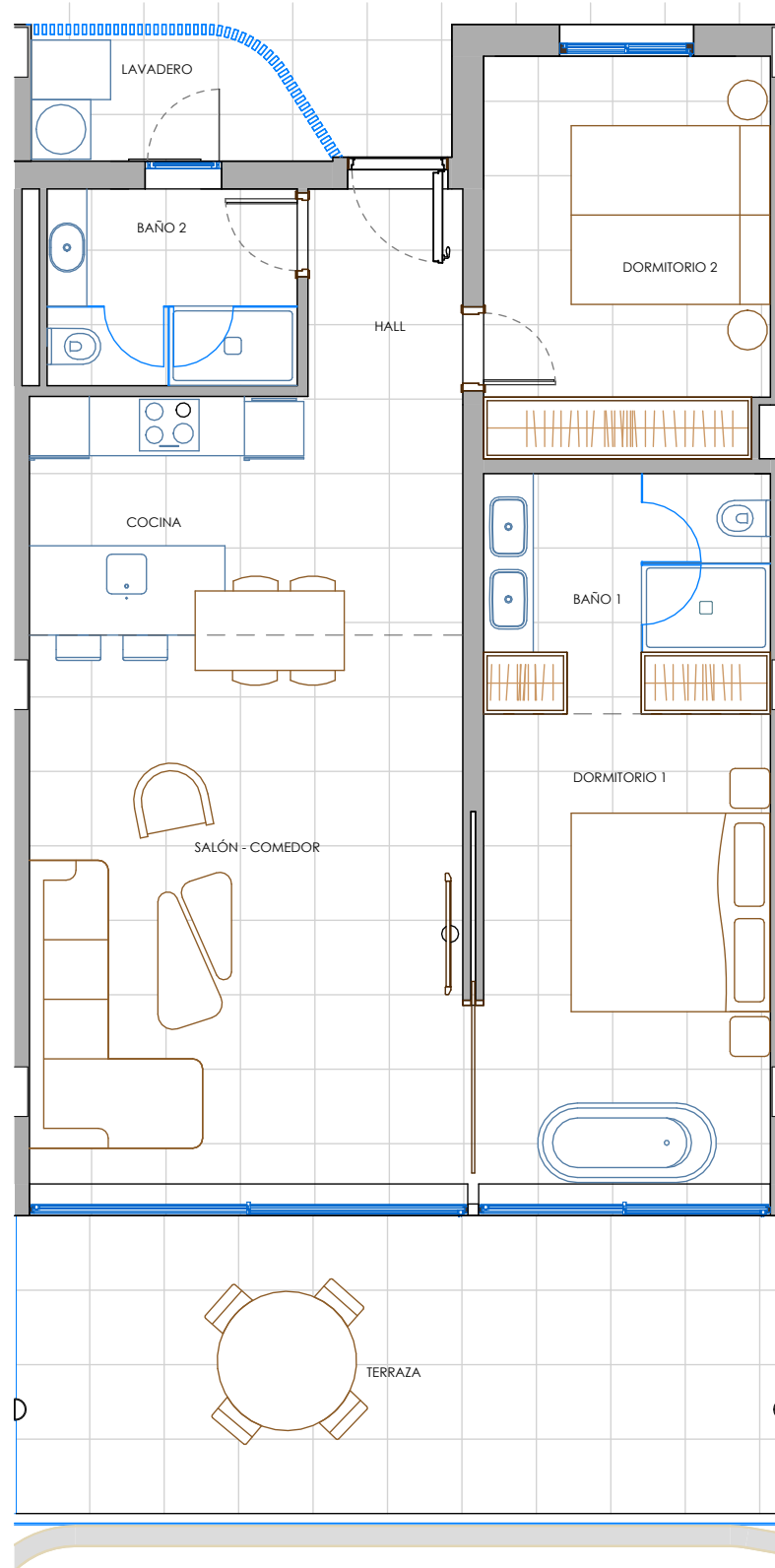

NIÁGARA (Módulo D2)  
P1 M  
Apartamento nº 208

SUPERFICIE CONSTRUIDA VIVIENDA..... 90.94 m<sup>2</sup>  
SUPERFICIE CONSTRUIDA TERRAZA..... 25.68 m<sup>2</sup>



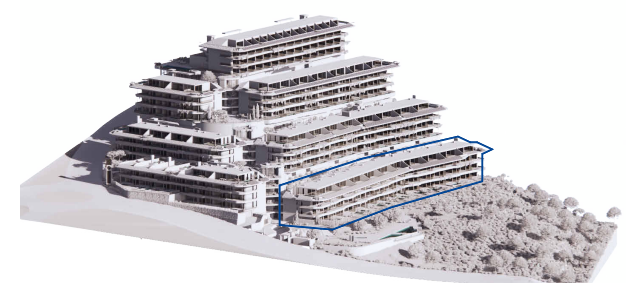
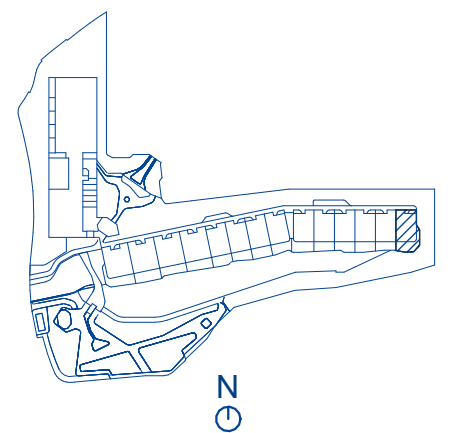
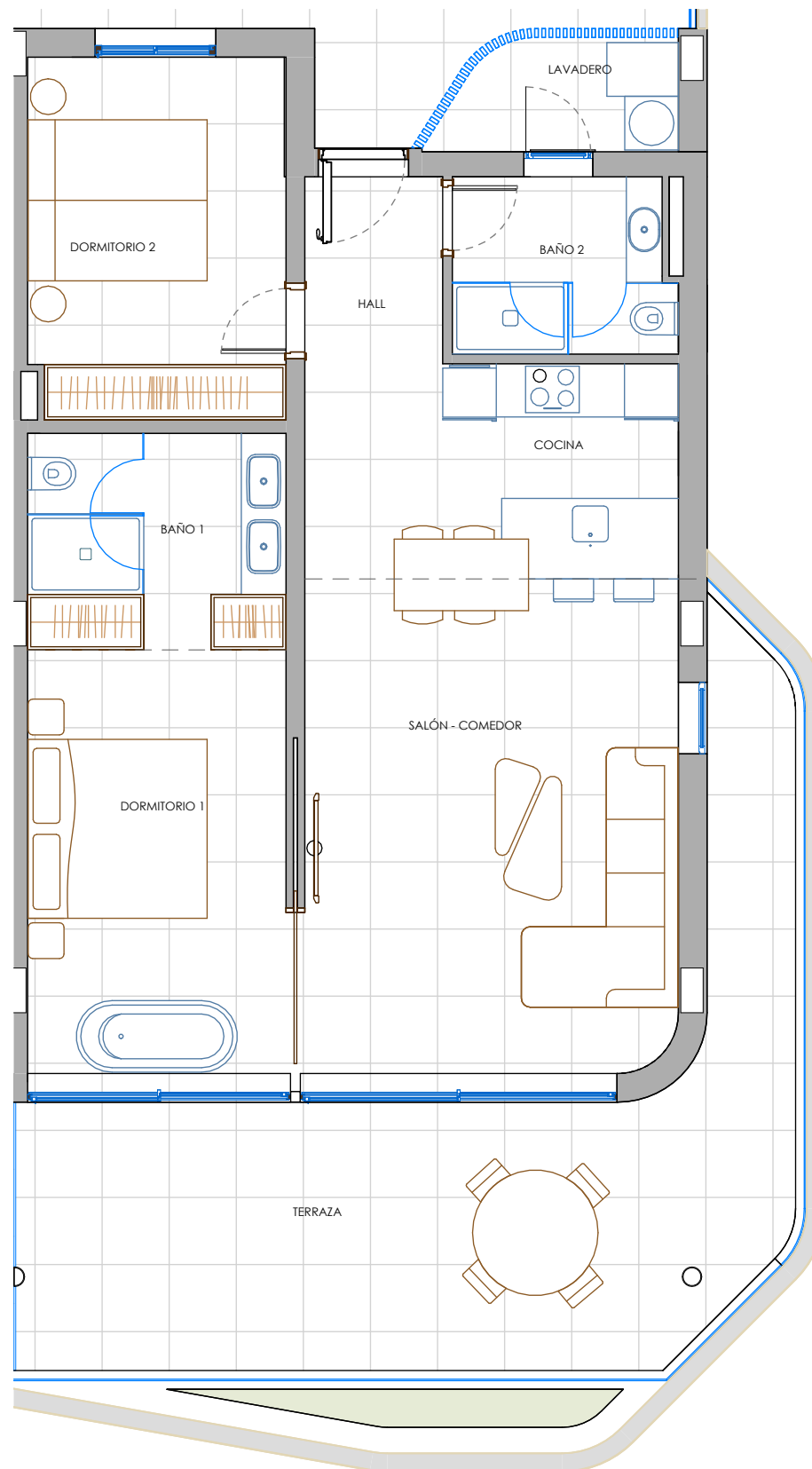

NIÁGARA (Módulo D2)  
P1 N  
Apartamento nº 209

SUPERFICIE CONSTRUIDA VIVIENDA..... 90.59 m<sup>2</sup>  
SUPERFICIE CONSTRUIDA TERRAZA..... 35.30 m<sup>2</sup>

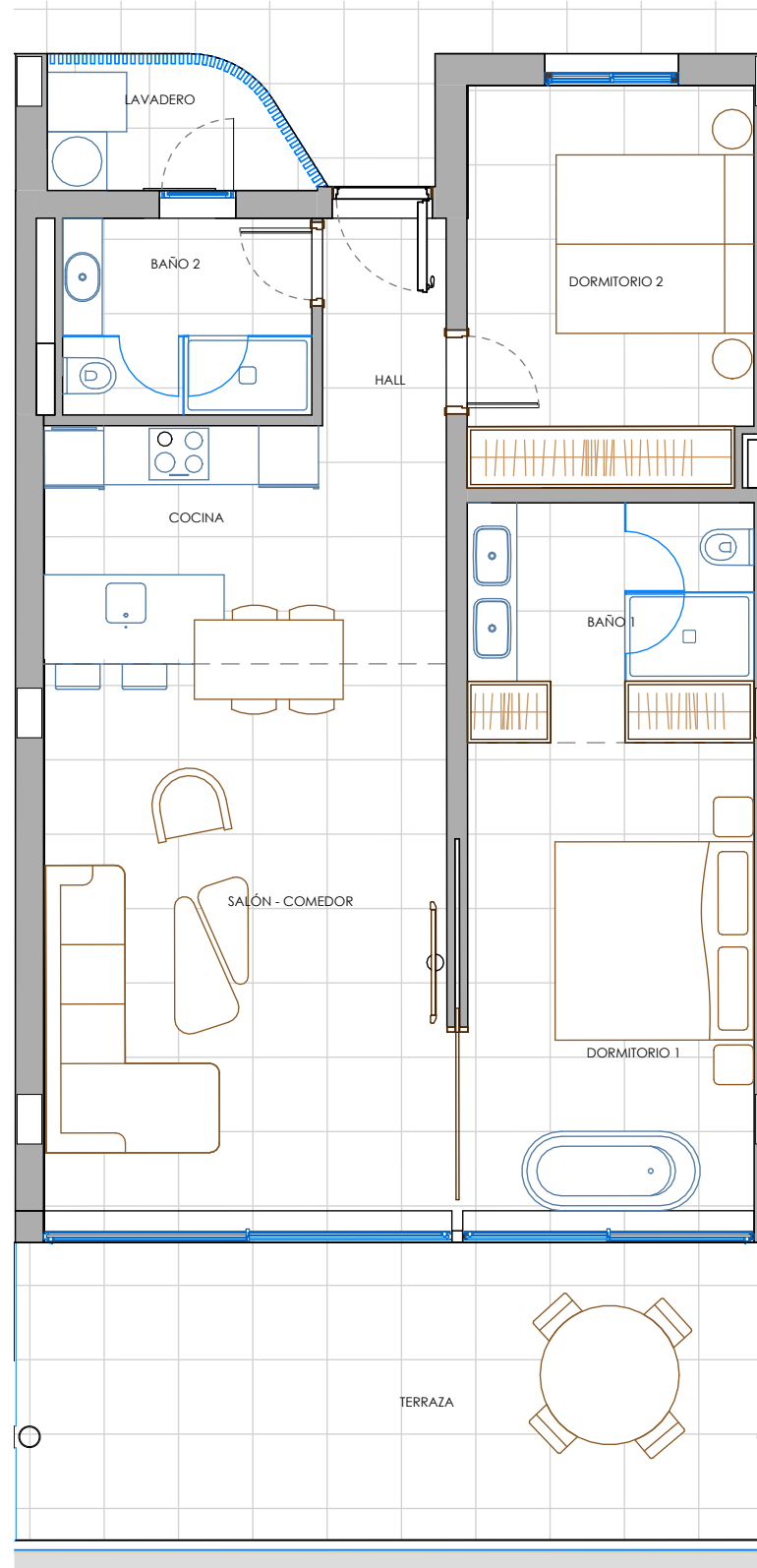

NIÁGARA (Módulo D2)  
P1 E  
Apartamento nº 200

SUPERFICIE CONSTRUIDA VIVIENDA..... 89.15 m<sup>2</sup>  
SUPERFICIE CONSTRUIDA TERRAZA..... 25.30 m<sup>2</sup>

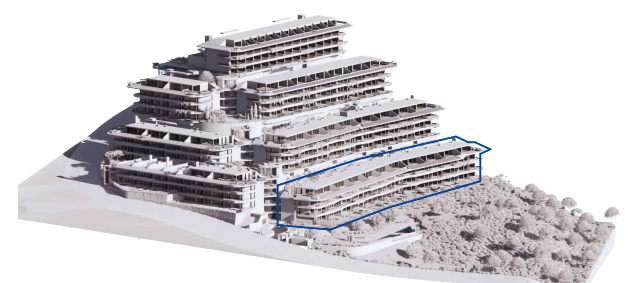
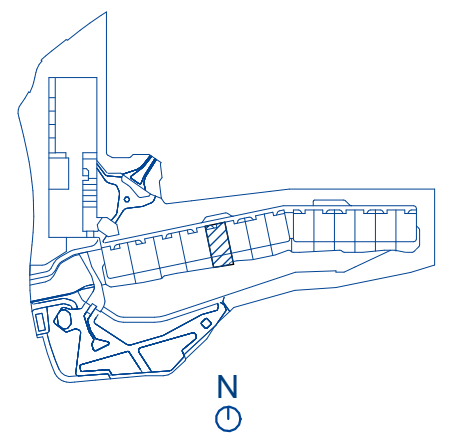

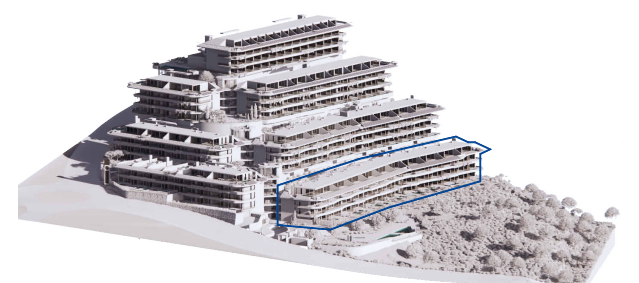
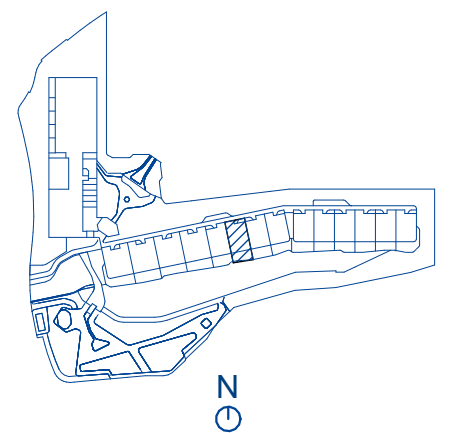
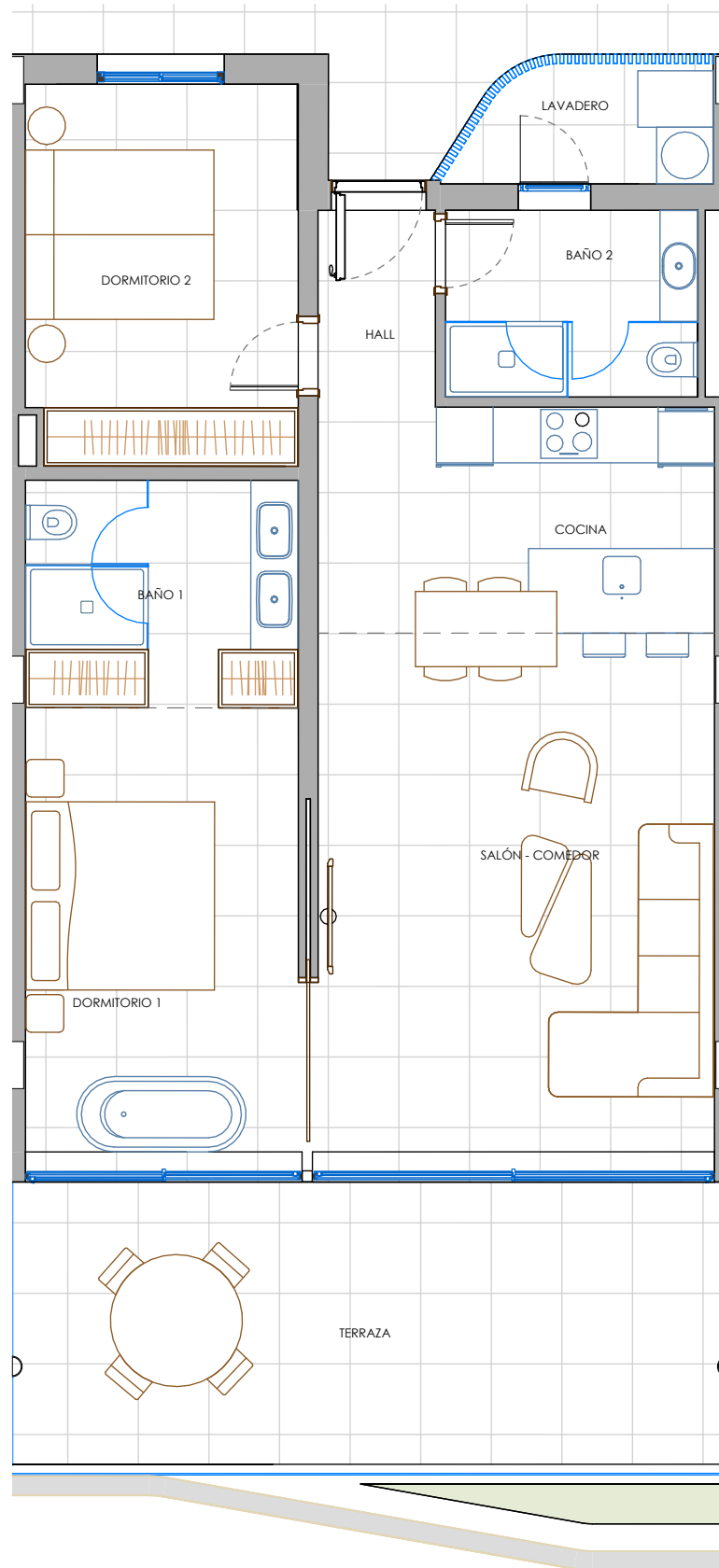

NIÁGARA (Módulo D2)  
P1 F  
Apartamento nº 201

SUPERFICIE CONSTRUIDA VIVIENDA..... 89.14 m<sup>2</sup>  
SUPERFICIE CONSTRUIDA TERRAZA..... 24.57 m<sup>2</sup>

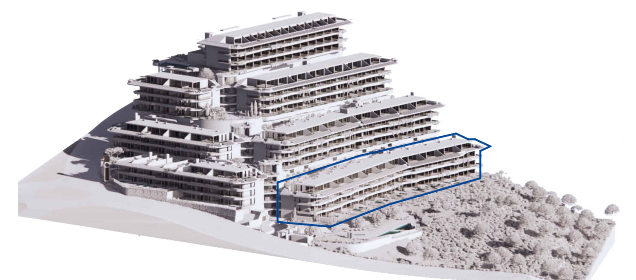
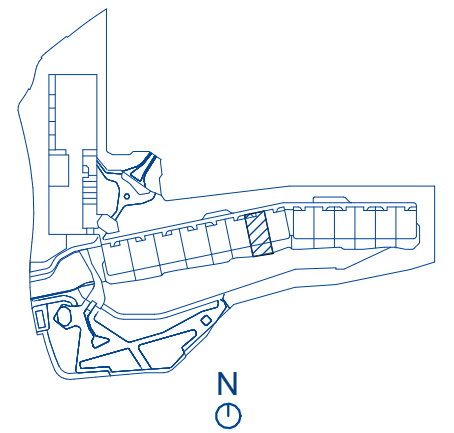
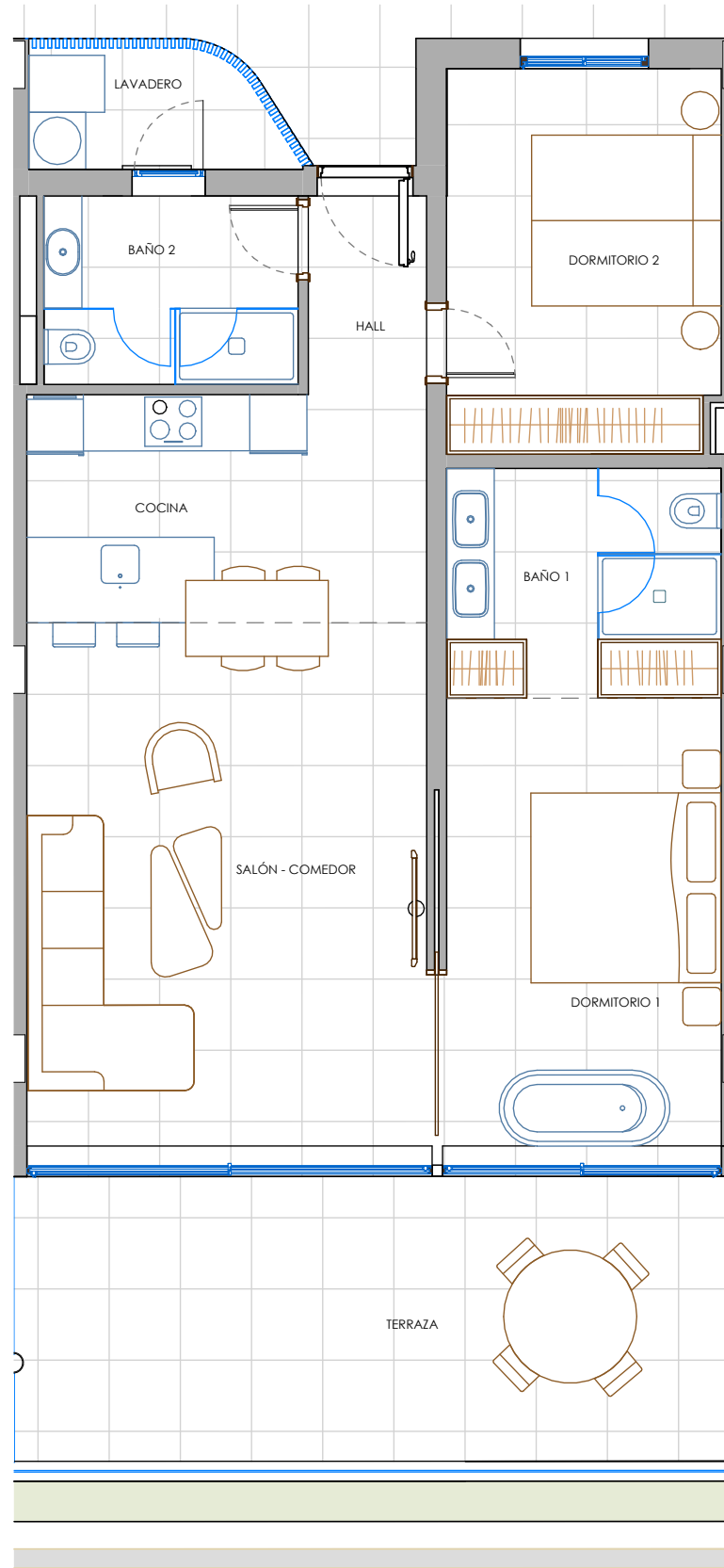

NIÁGARA (Módulo D2)  
P1 G  
Apartamento nº 202

SUPERFICIE CONSTRUIDA VIVIENDA..... 89.03 m<sup>2</sup>  
SUPERFICIE CONSTRUIDA TERRAZA..... 24.46 m<sup>2</sup>

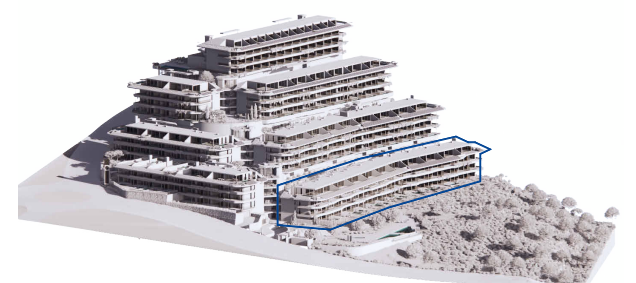
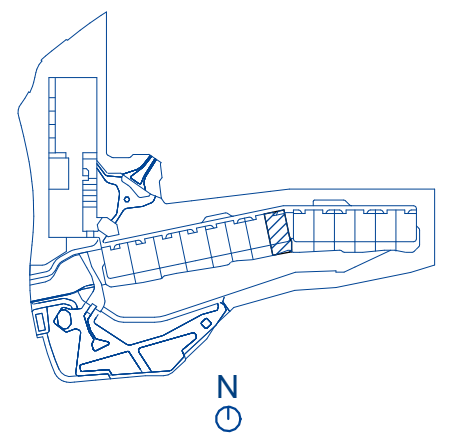
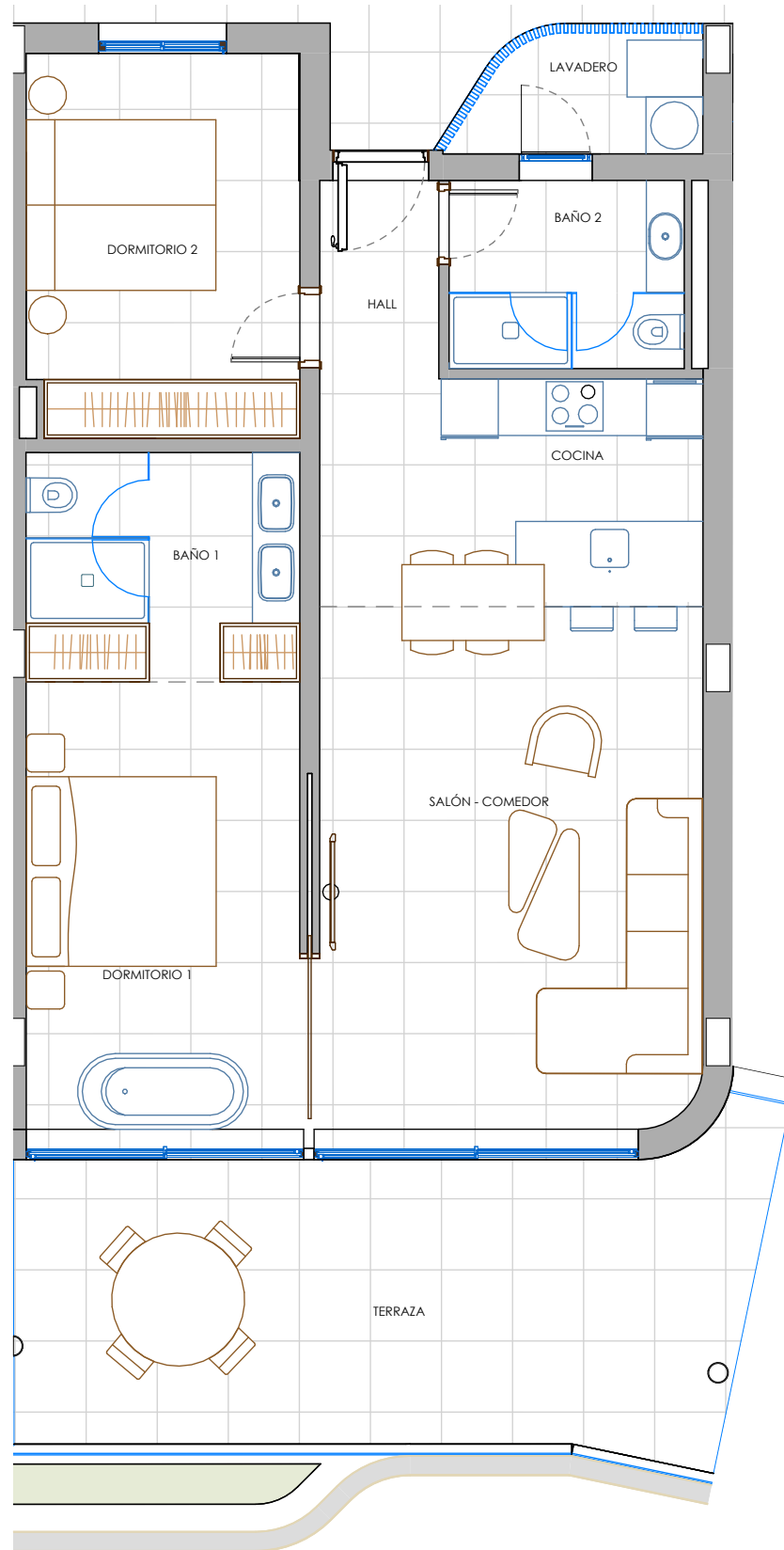

NIÁGARA (Módulo D2)  
P1 H  
Apartamento nº 203

SUPERFICIE CONSTRUIDA VIVIENDA..... 88.84 m<sup>2</sup>  
SUPERFICIE CONSTRUIDA TERRAZA..... 26.19 m<sup>2</sup>

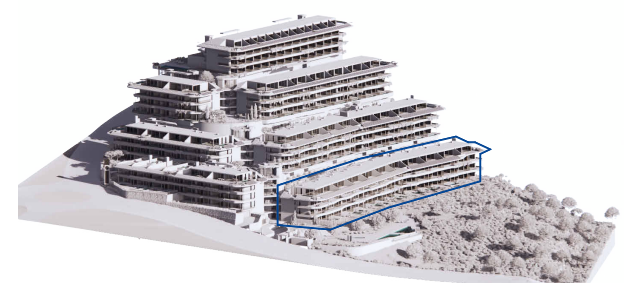
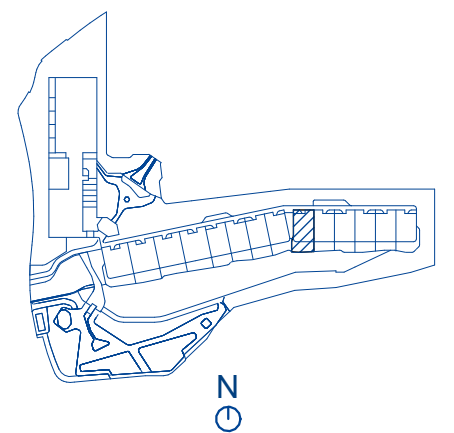
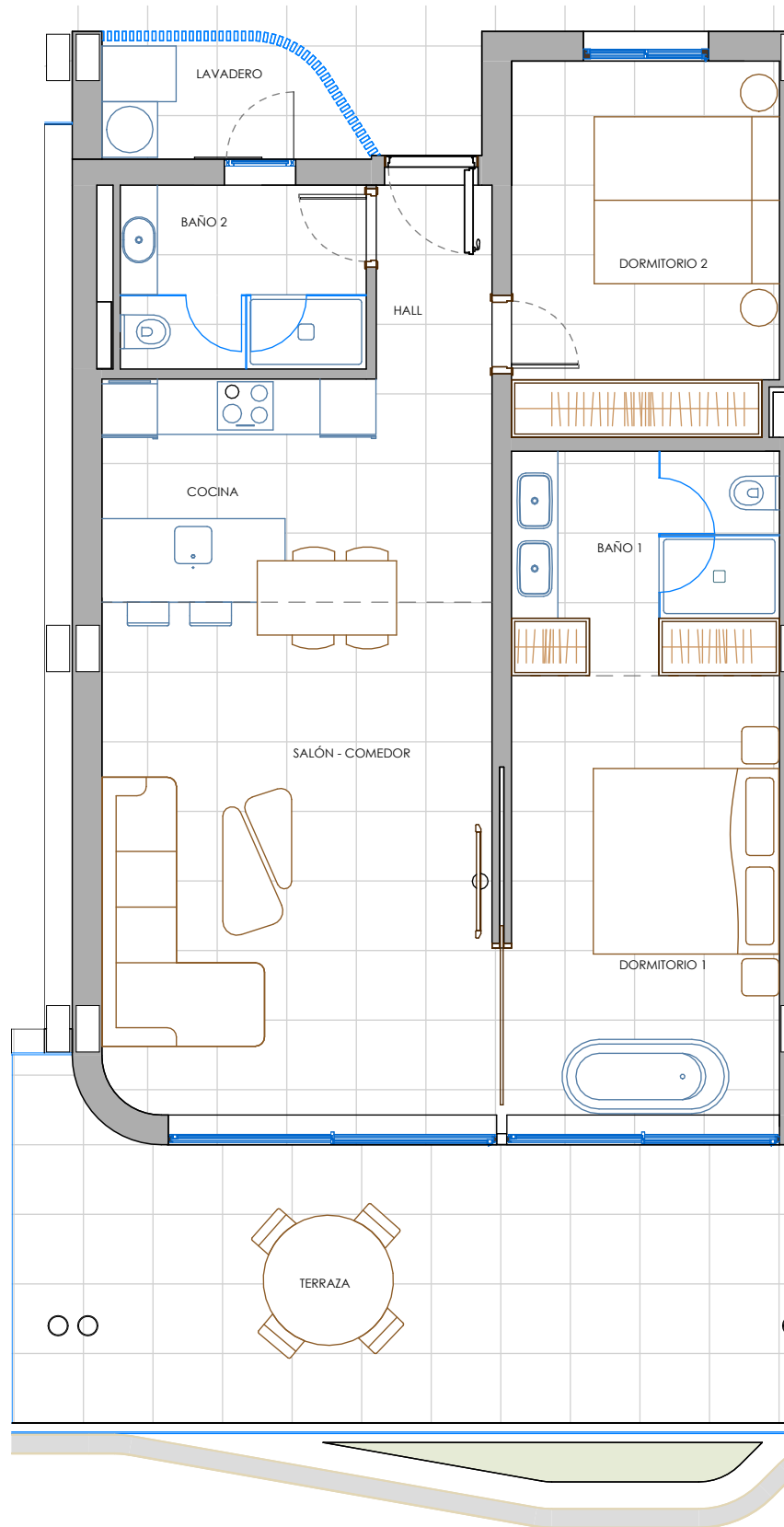

NIÁGARA (Módulo D2)  
P1 I  
Apartamento nº 204

SUPERFICIE CONSTRUIDA VIVIENDA..... 90.94 m<sup>2</sup>  
SUPERFICIE CONSTRUIDA TERRAZA..... 28.21 m<sup>2</sup>

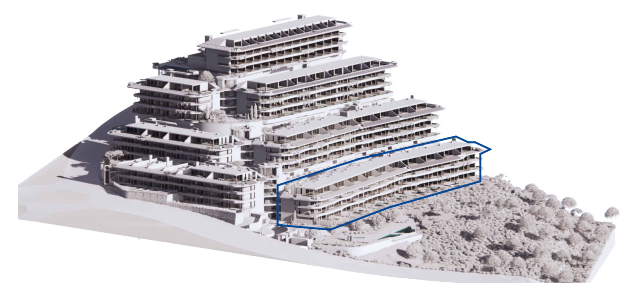
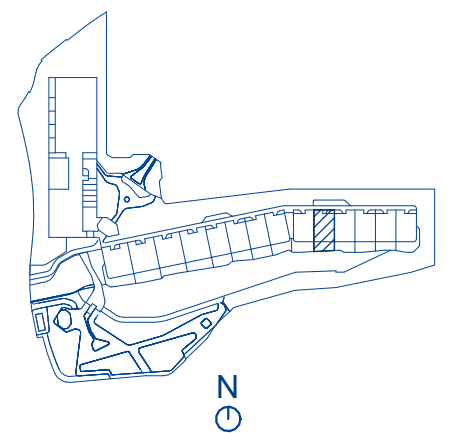
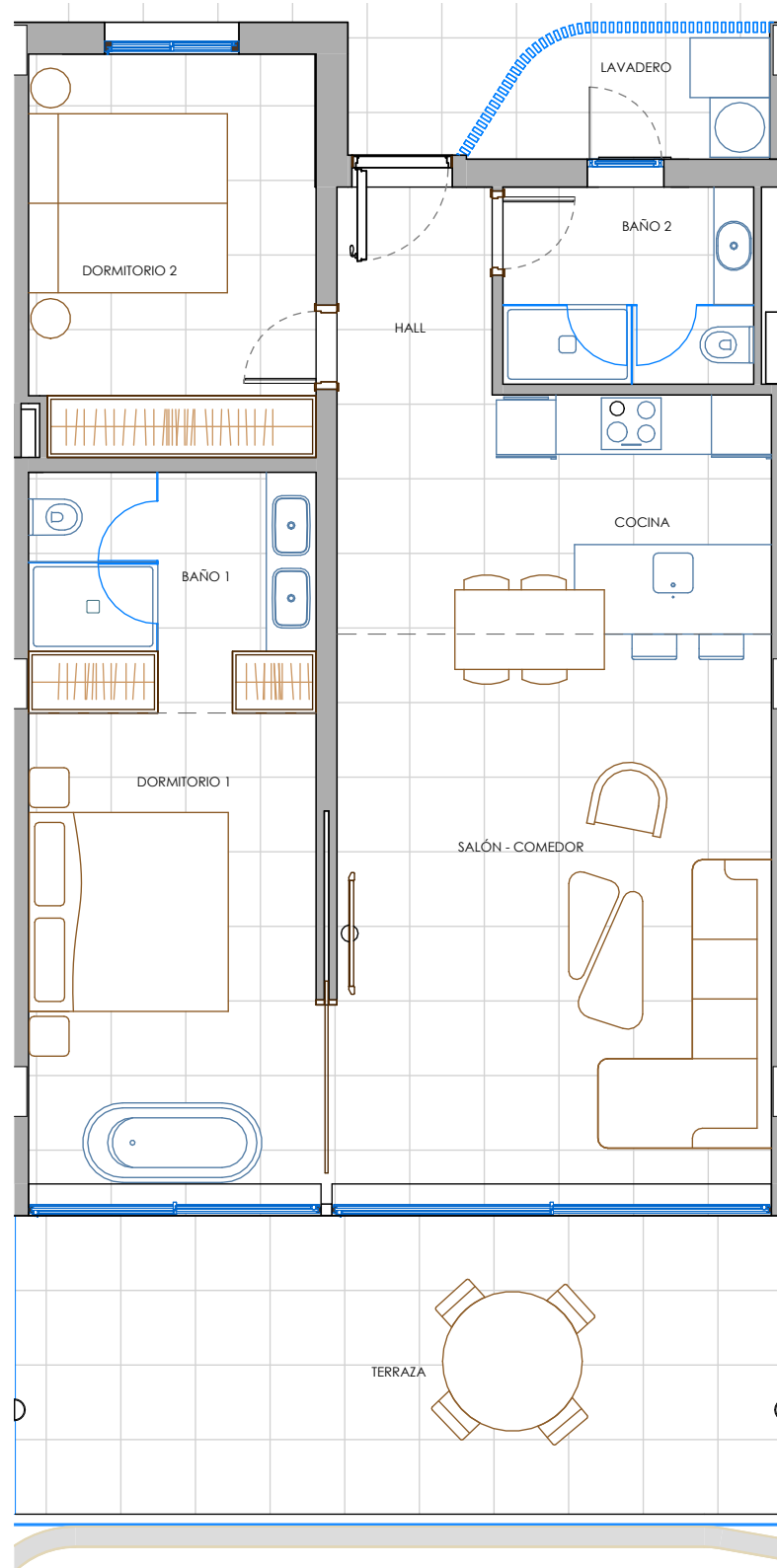

NIÁGARA (Módulo D2)  
P1 J  
Apartamento nº 205

SUPERFICIE CONSTRUIDA VIVIENDA..... 90.89 m<sup>2</sup>  
SUPERFICIE CONSTRUIDA TERRAZA..... 25.65 m<sup>2</sup>



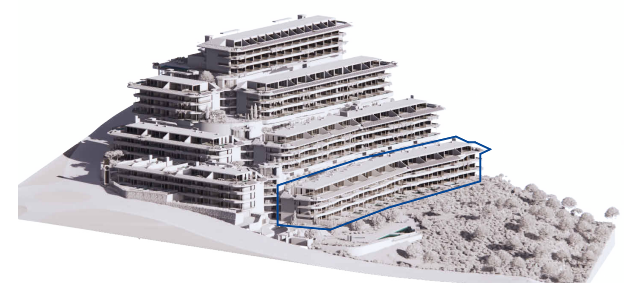
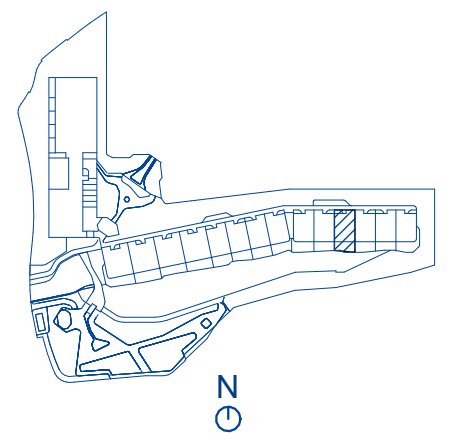
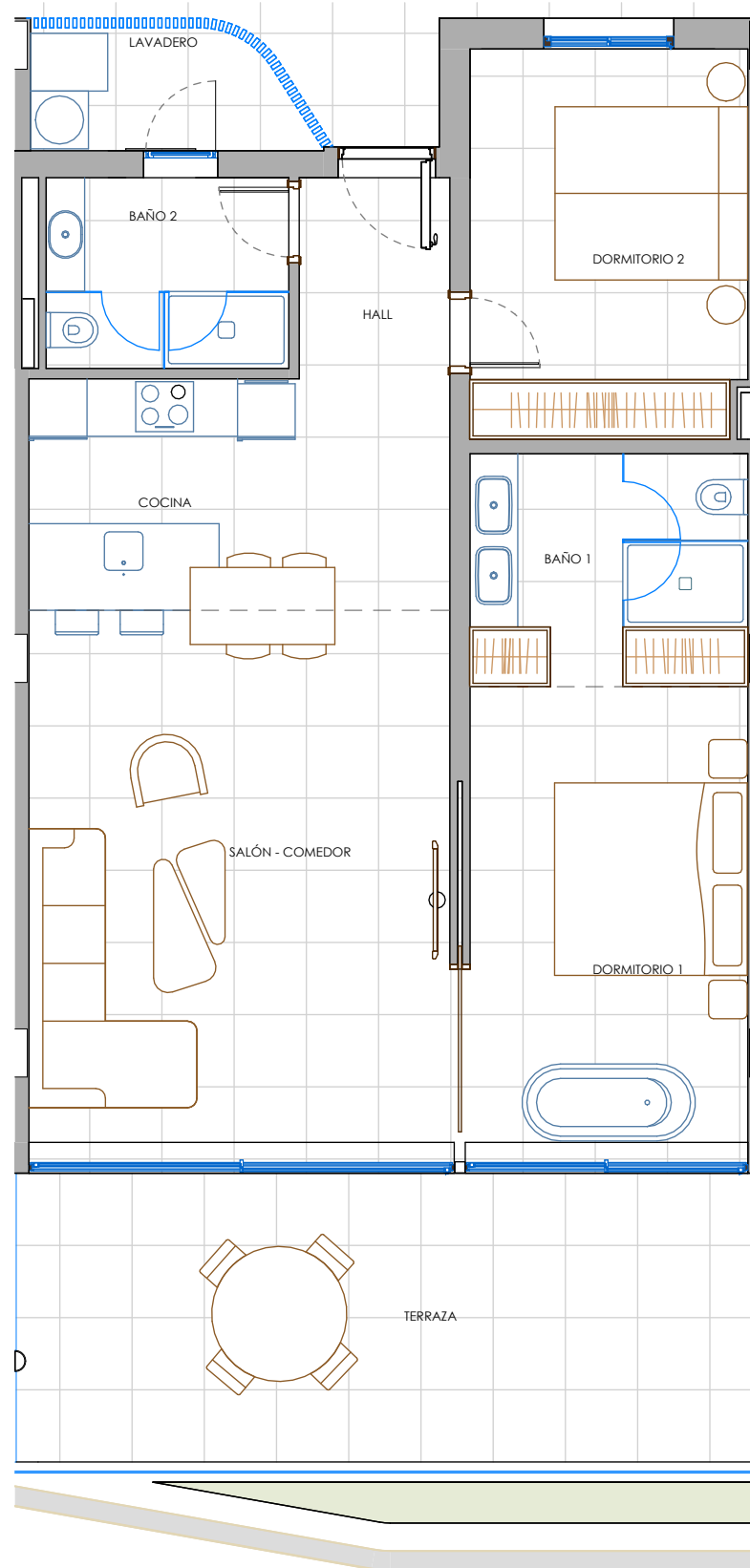

NIÁGARA (Módulo D2)  
P1 K  
Apartamento nº 206

SUPERFICIE CONSTRUIDA VIVIENDA..... 90.97 m<sup>2</sup>  
SUPERFICIE CONSTRUIDA TERRAZA..... 24.89 m<sup>2</sup>

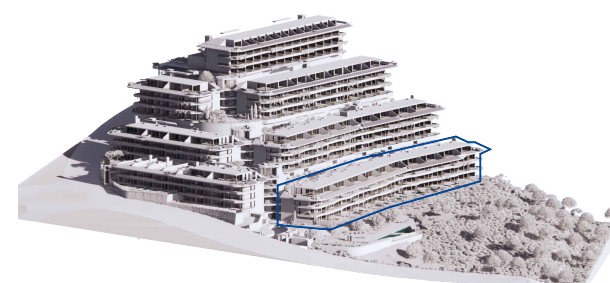
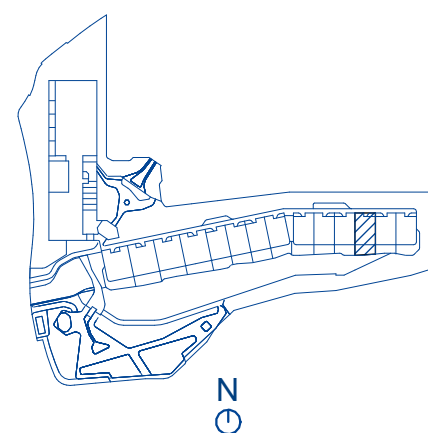
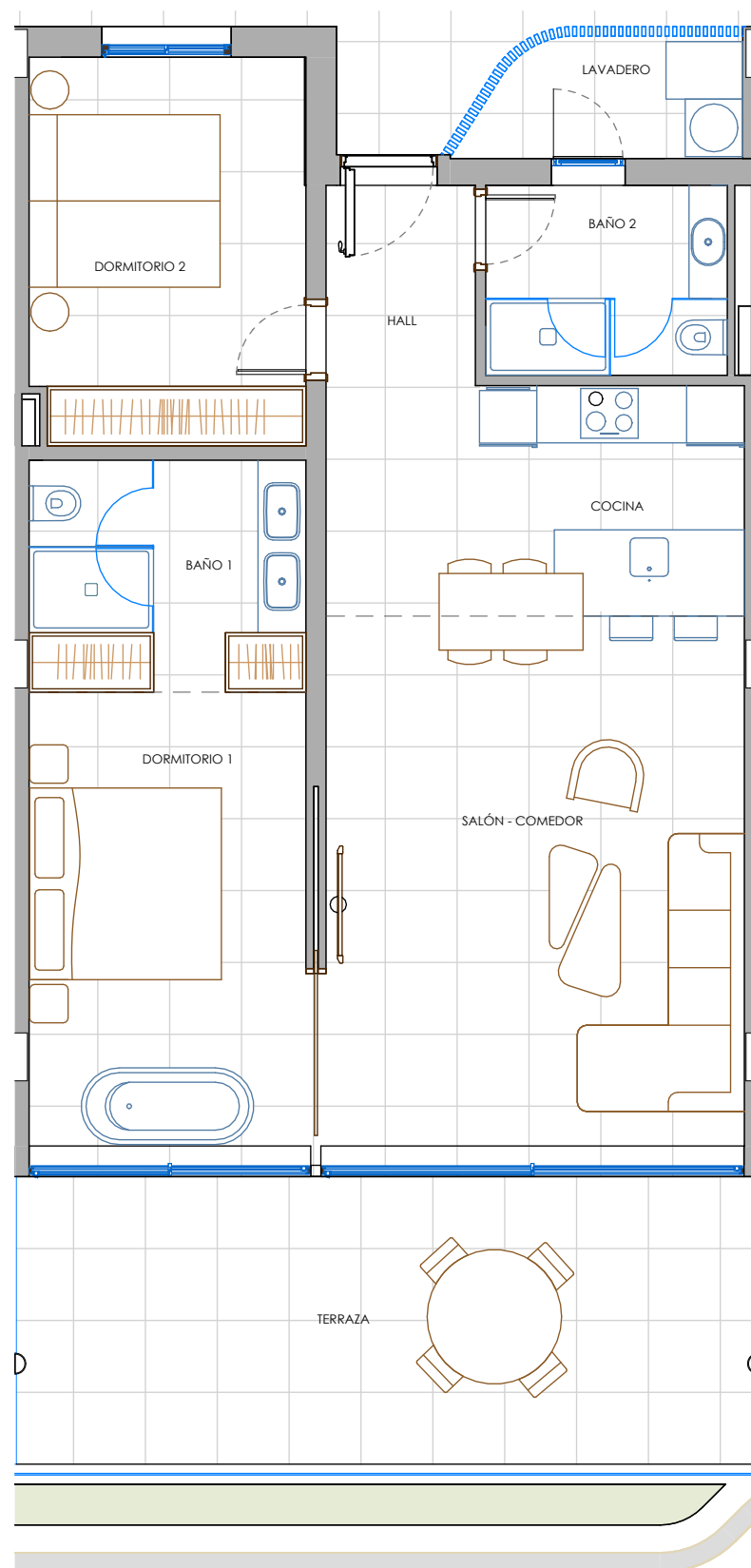

NIÁGARA (Módulo D2)  
P1 L  
Apartamento nº 207

SUPERFICIE CONSTRUIDA VIVIENDA..... 90.87 m<sup>2</sup>  
SUPERFICIE CONSTRUIDA TERRAZA..... 24.92 m<sup>2</sup>

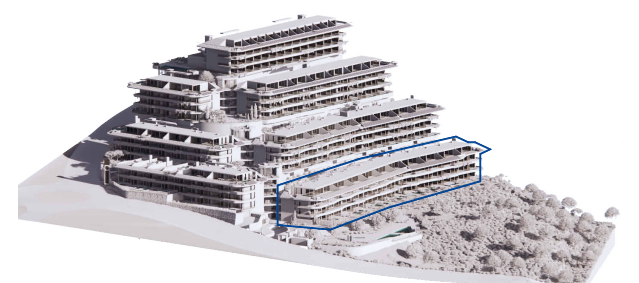
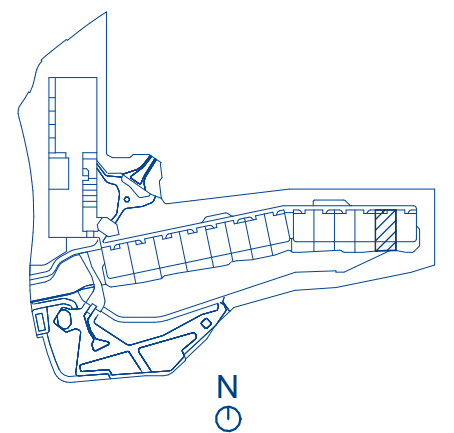
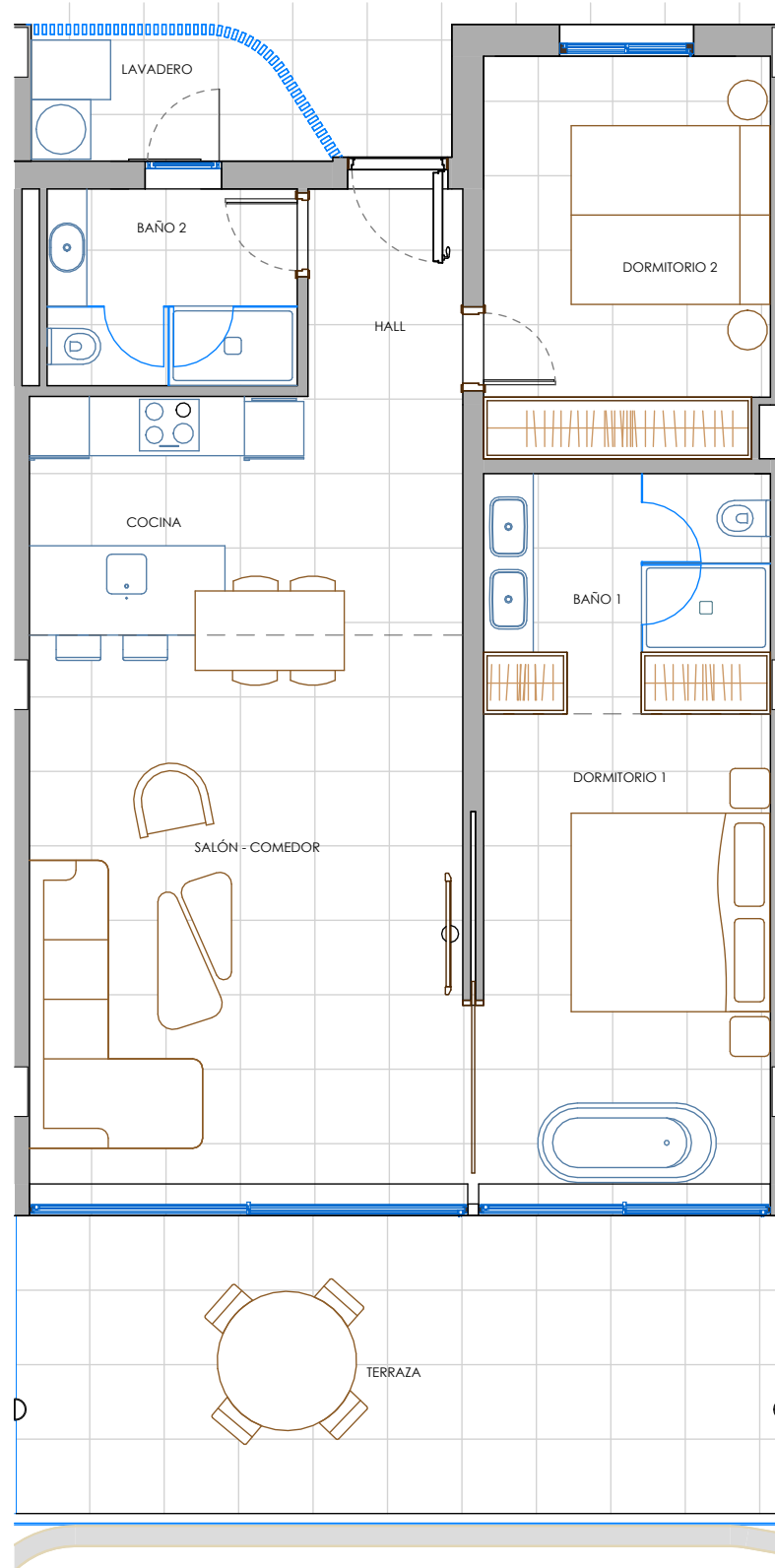

NIÁGARA (Módulo D2)  
P1 M  
Apartamento nº 208

SUPERFICIE CONSTRUIDA VIVIENDA..... 90.94 m<sup>2</sup>  
SUPERFICIE CONSTRUIDA TERRAZA..... 25.68 m<sup>2</sup>

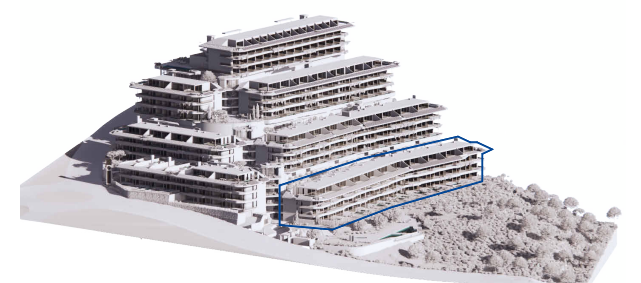
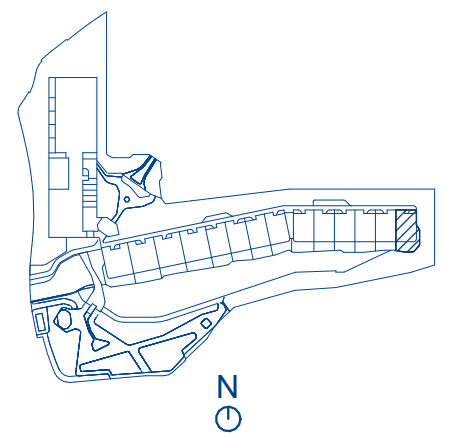
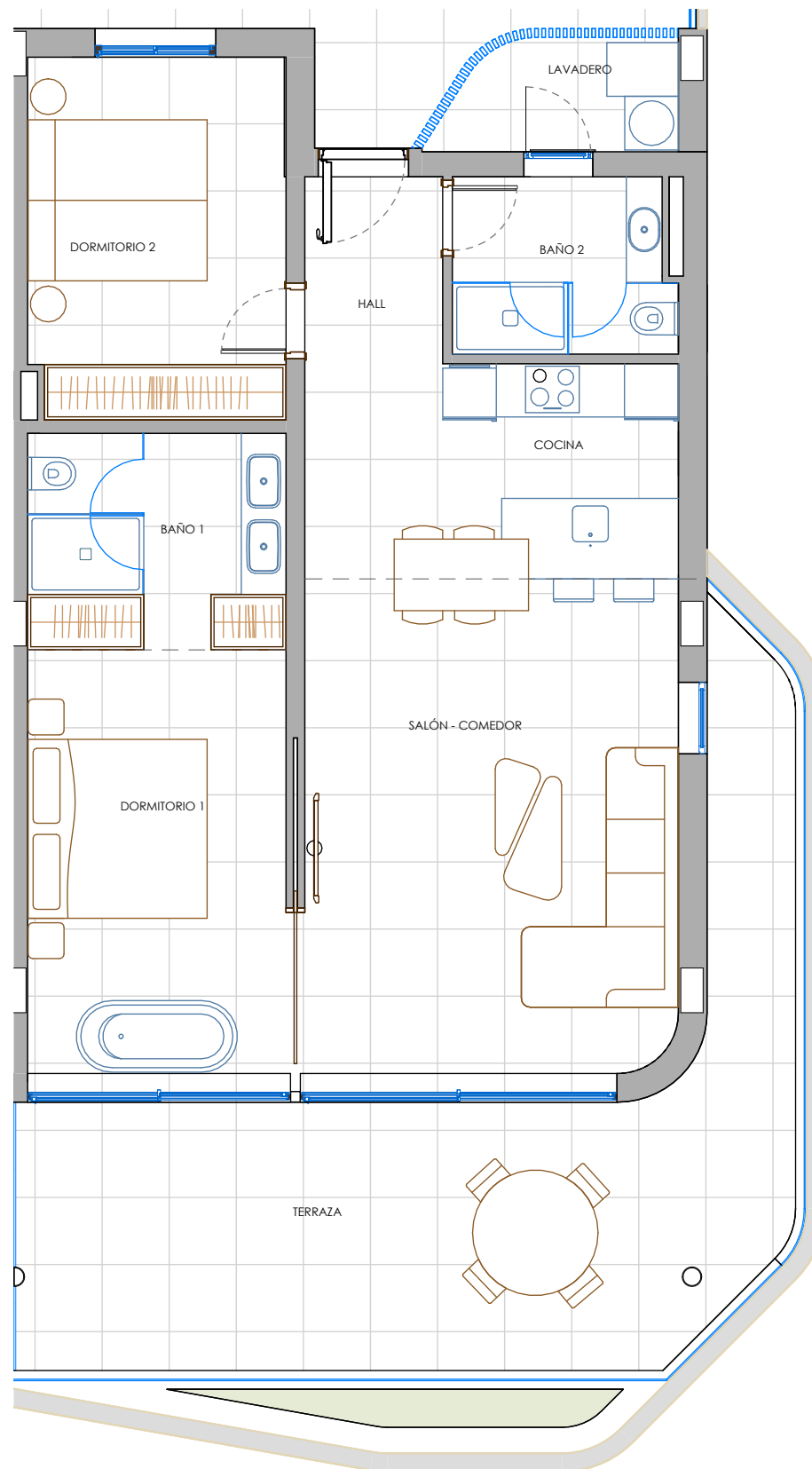

NIÁGARA (Módulo D2)  
P1 N  
Apartamento nº 209

SUPERFICIE CONSTRUIDA VIVIENDA..... 90.59 m<sup>2</sup>  
SUPERFICIE CONSTRUIDA TERRAZA..... 35.30 m<sup>2</sup>

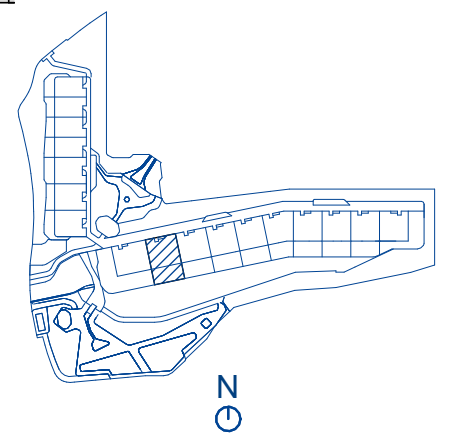
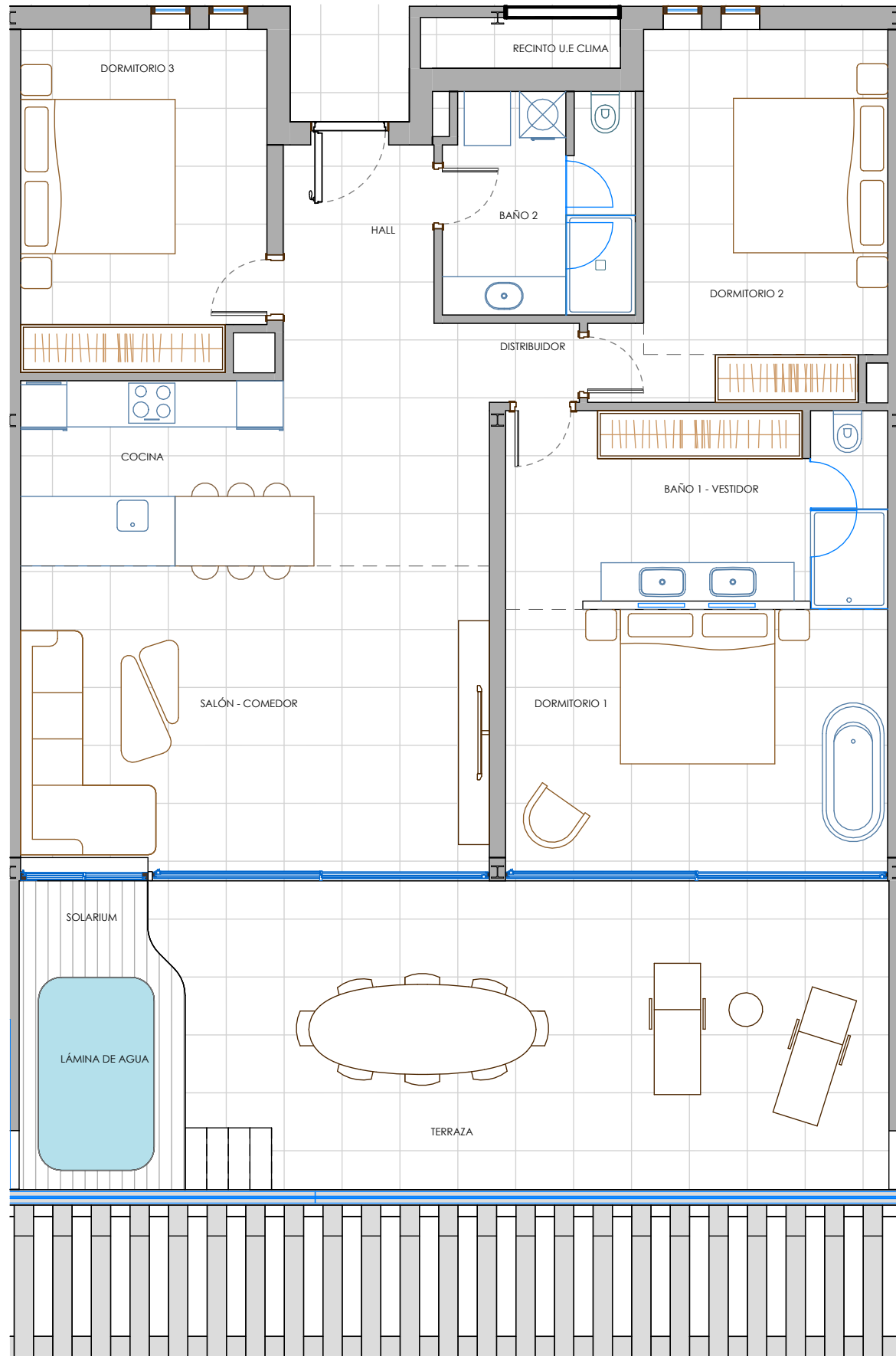

NIÁGARA (Módulo D2)  
Ático B  
Apartamento nº 225

SUPERFICIE CONSTRUIDA VIVIENDA.....	128.14 m <sup>2</sup>
SUPERFICIE CONSTRUIDA TERRAZA.....	40.26 m <sup>2</sup>
SUPERFICIE LÁMINA DE AGUA & SOLARIUM....	8.10 m <sup>2</sup>
<b>SUPERFICIE EXTERIOR TOTAL</b>	<b>48.36 m<sup>2</sup></b>

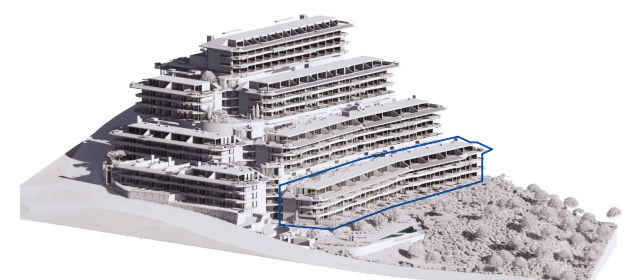

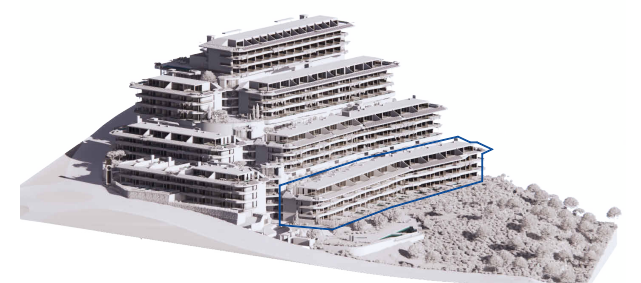
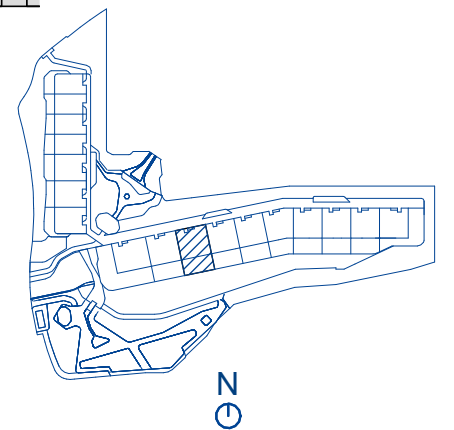
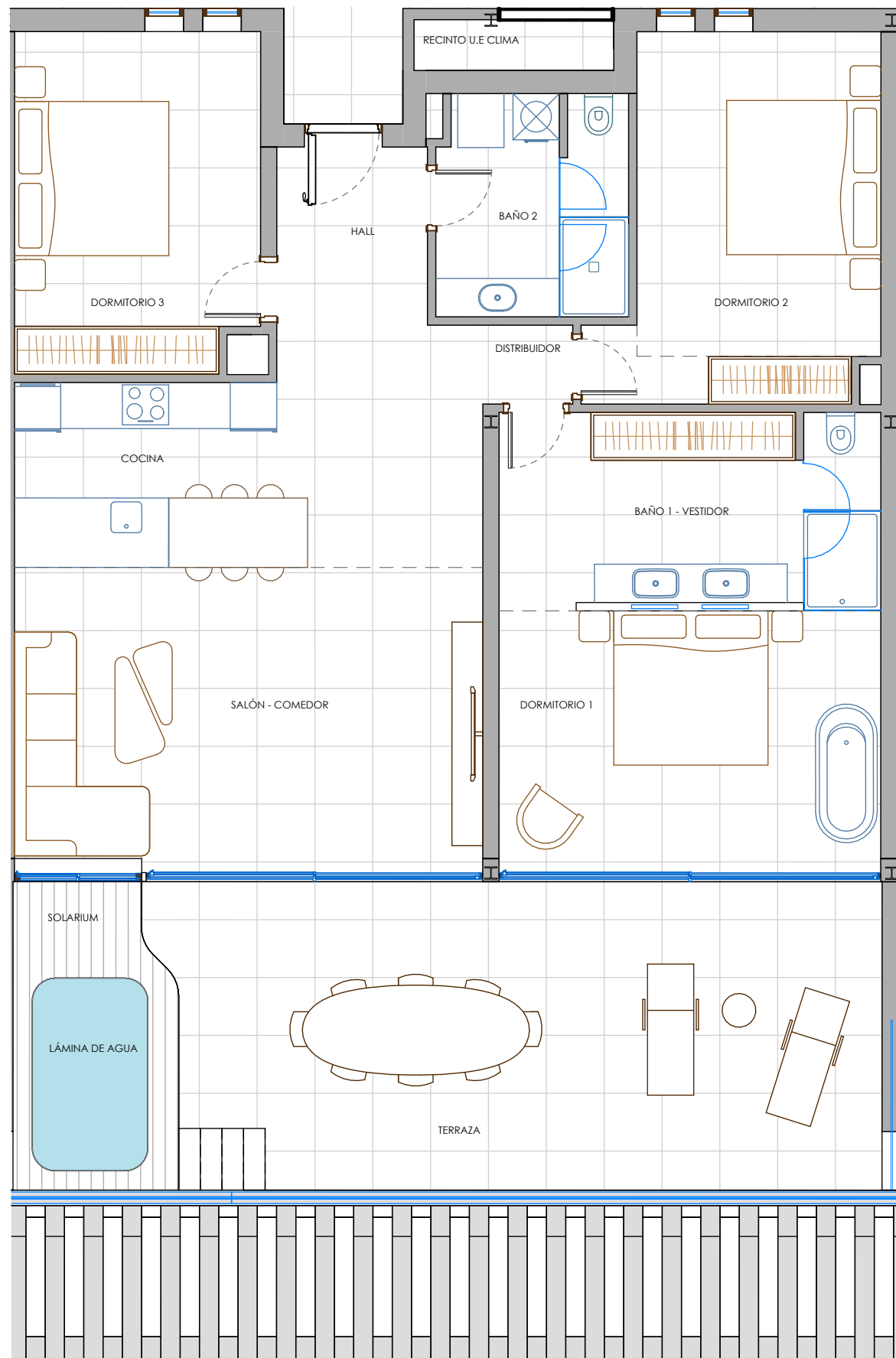

NIÁGARA (Módulo D2)  
Ático C  
Apartamento nº 226

SUPERFICIE CONSTRUIDA VIVIENDA.....130.06 m<sup>2</sup>  
 SUPERFICIE CONSTRUIDA TERRAZA.....40.98 m<sup>2</sup>  
 SUPERFICIE LÁMINA DE AGUA & SOLARIUM....8.10 m<sup>2</sup>  
**SUPERFICIE EXTERIOR TOTAL 49.08 m<sup>2</sup>**

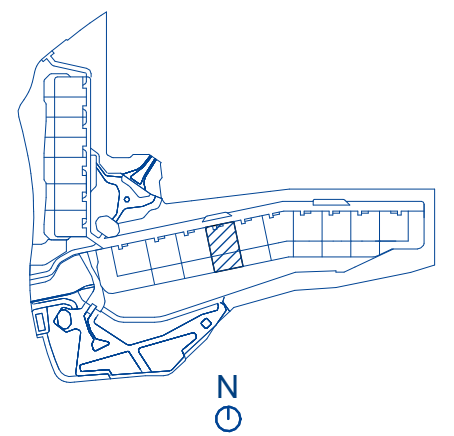
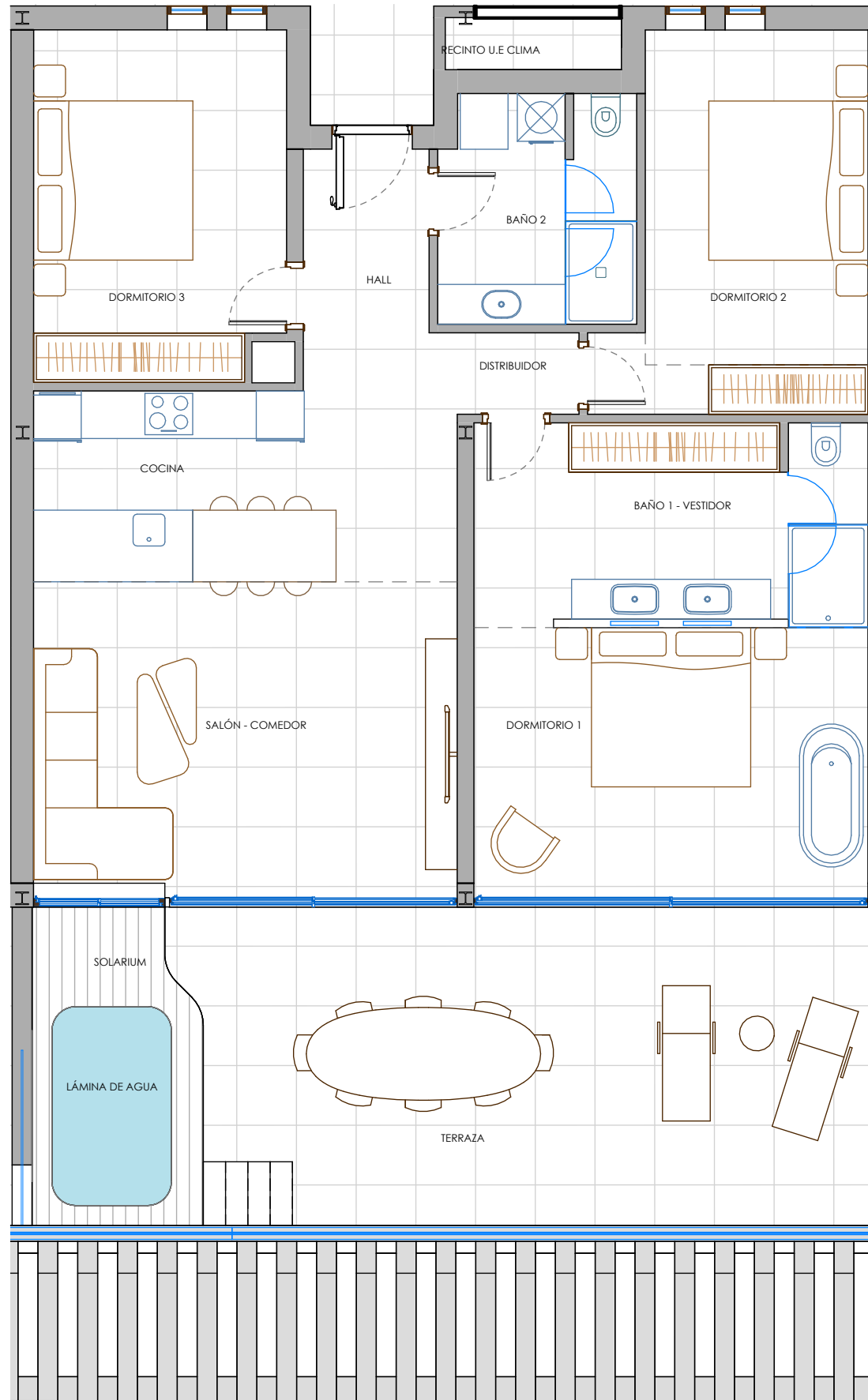

NIÁGARA (Módulo D2)  
Ático D  
Apartamento nº 227

SUPERFICIE CONSTRUIDA VIVIENDA.....121.32 m<sup>2</sup>  
 SUPERFICIE CONSTRUIDA TERRAZA.....37.77 m<sup>2</sup>  
 SUPERFICIE LÁMINA DE AGUA & SOLARIUM....8.10 m<sup>2</sup>  
**SUPERFICIE EXTERIOR TOTAL 45.87 m<sup>2</sup>**

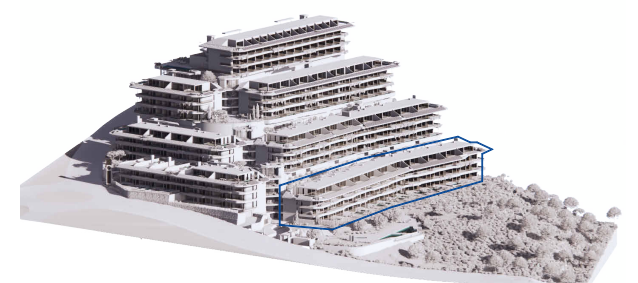



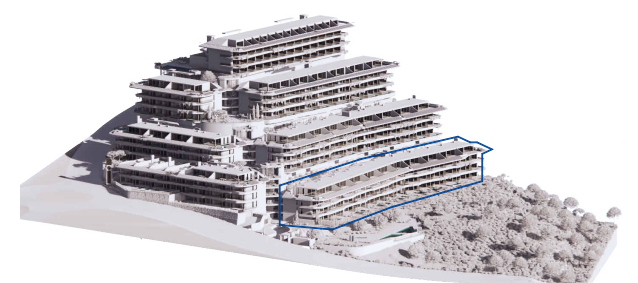
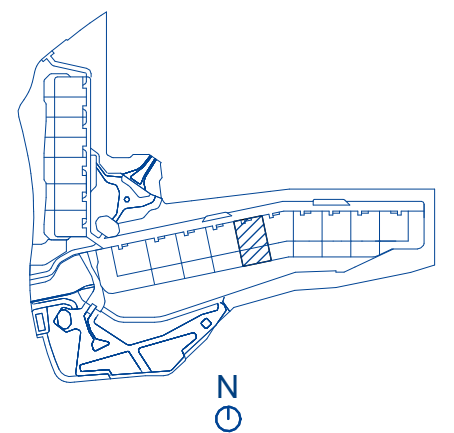
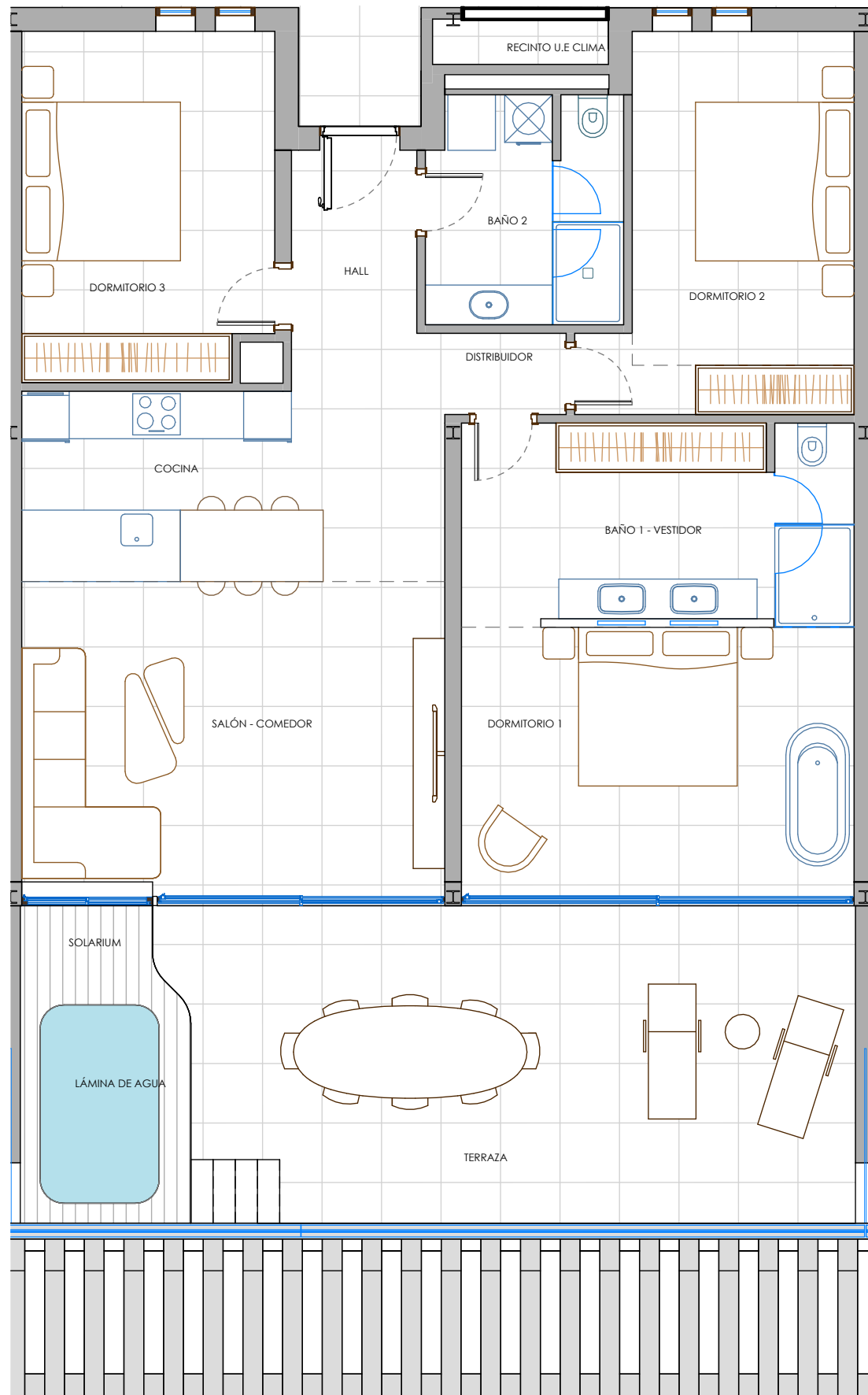

NIÁGARA (Módulo D2)  
Ático E  
Apartamento nº 228

SUPERFICIE CONSTRUIDA VIVIENDA.....119.70 m<sup>2</sup>  
 SUPERFICIE CONSTRUIDA TERRAZA.....37.17 m<sup>2</sup>  
 SUPERFICIE LÁMINA DE AGUA & SOLARIUM....8.10 m<sup>2</sup>  
**SUPERFICIE EXTERIOR TOTAL 45.27 m<sup>2</sup>**

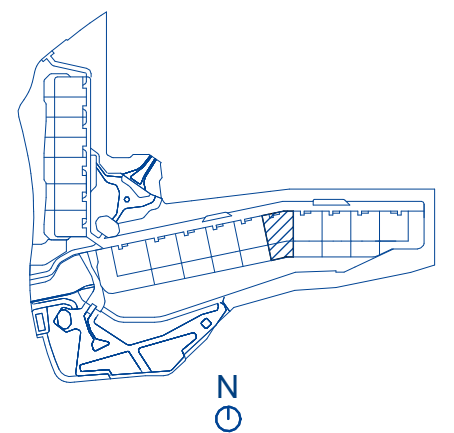
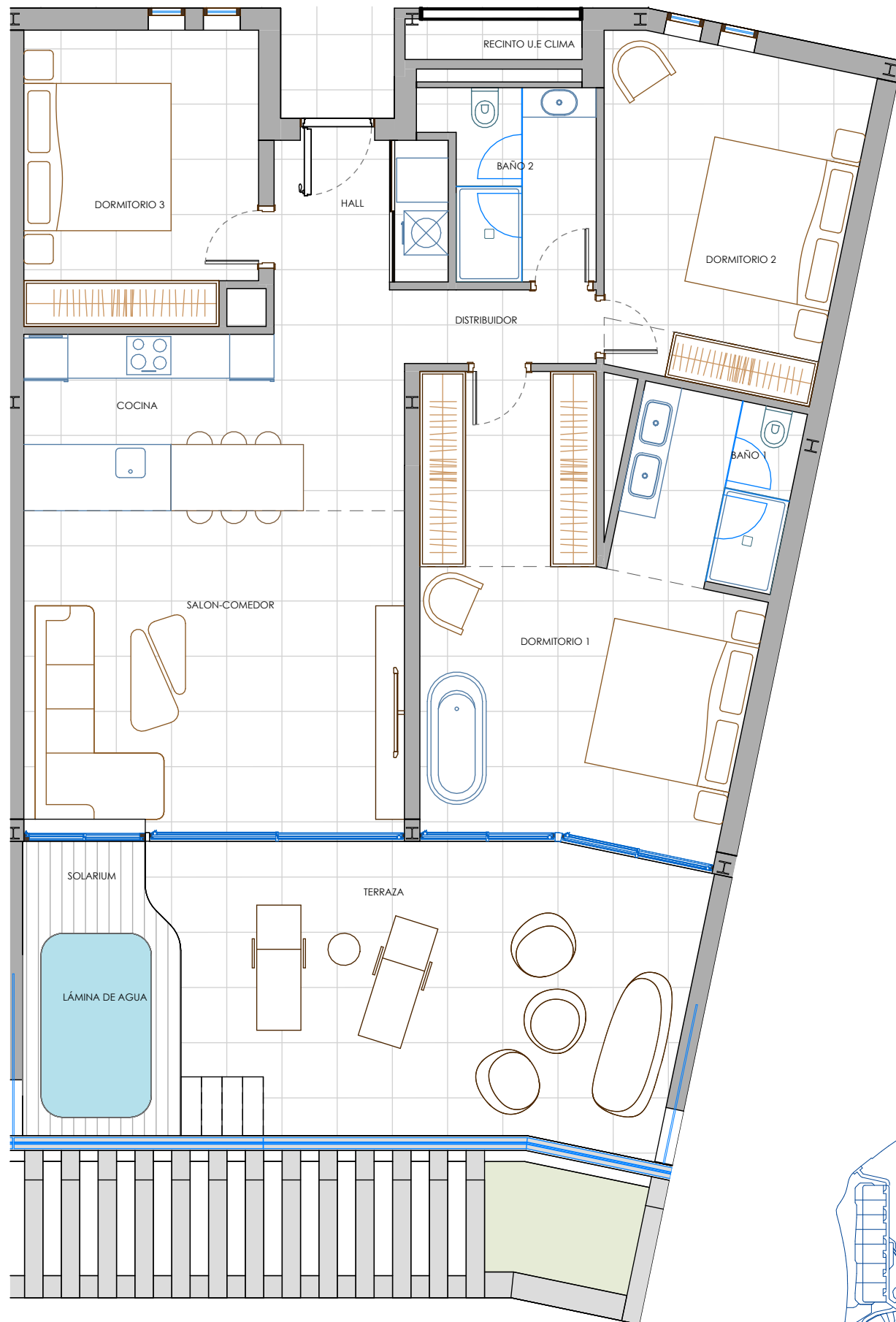

NIÁGARA (Módulo D2)  
Ático F  
Apartamento nº 229

SUPERFICIE CONSTRUIDA VIVIENDA.....122.19 m<sup>2</sup>  
 SUPERFICIE CONSTRUIDA TERRAZA.....31.38 m<sup>2</sup>  
 SUPERFICIE LÁMINA DE AGUA & SOLARIUM....8.10 m<sup>2</sup>  
**SUPERFICIE EXTERIOR TOTAL 39.48 m<sup>2</sup>**

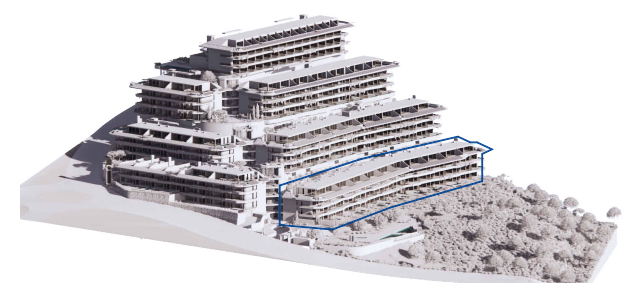

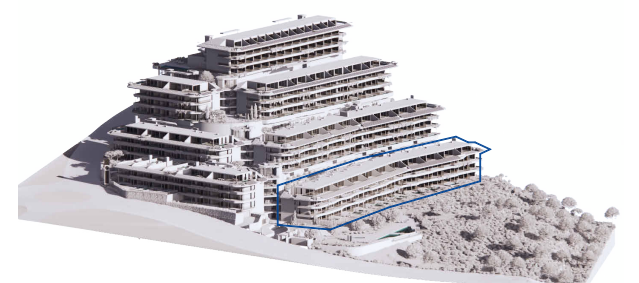
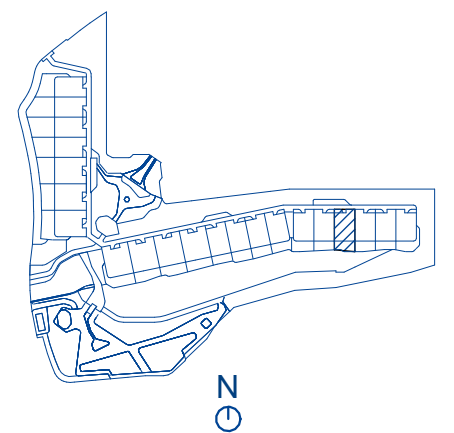
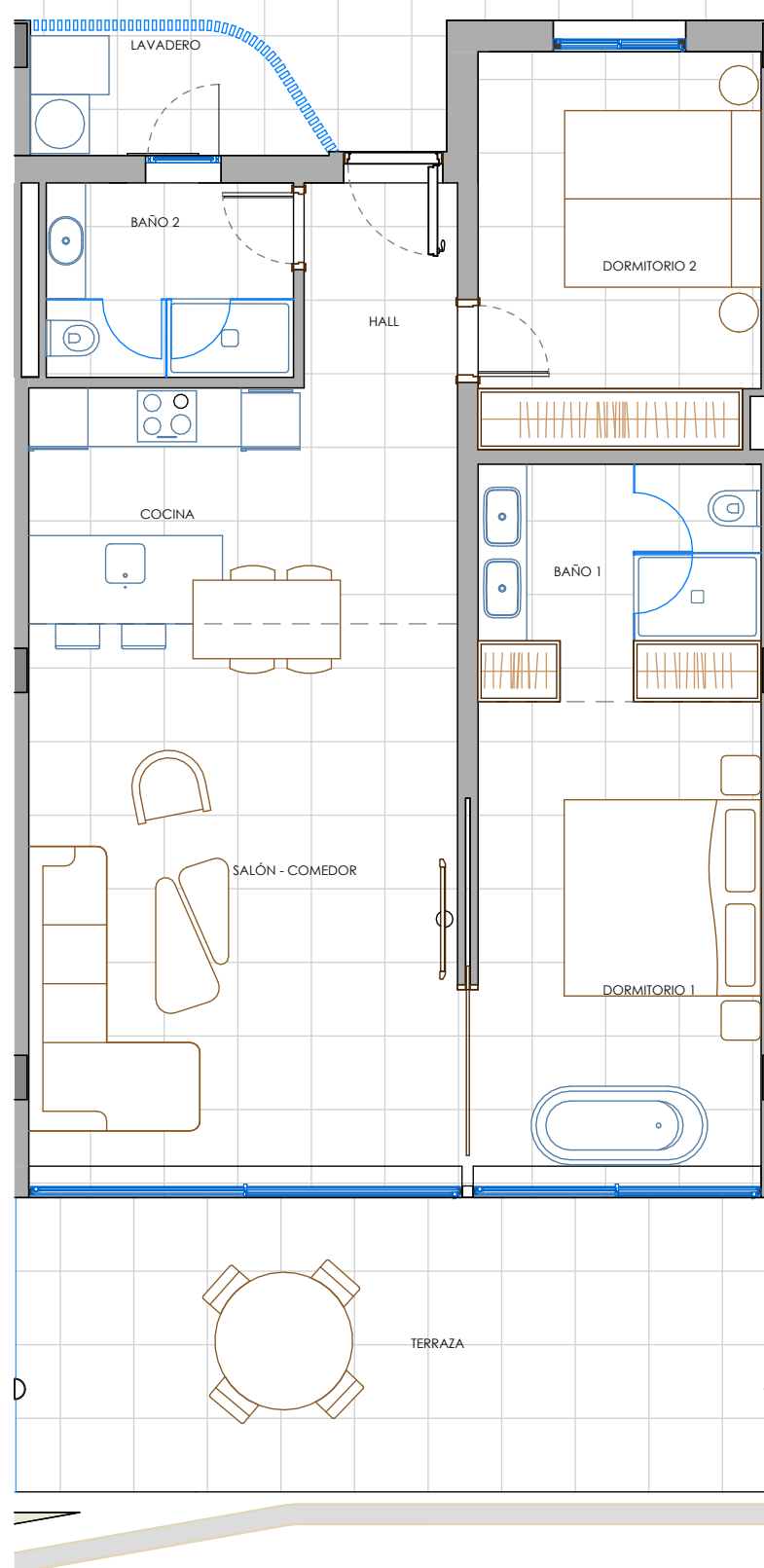

NIÁGARA (Módulo D2)  
P2 K  
Apartamento nº 220

SUPERFICIE CONSTRUIDA VIVIENDA..... 90.97 m<sup>2</sup>  
SUPERFICIE CONSTRUIDA TERRAZA..... 25.46 m<sup>2</sup>

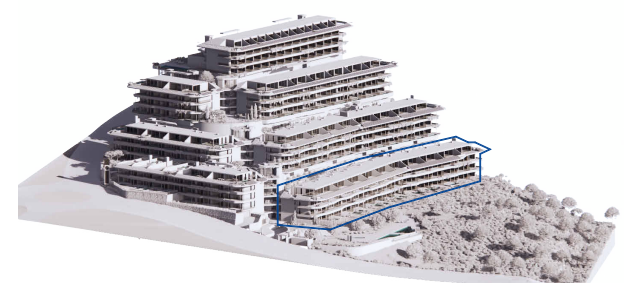
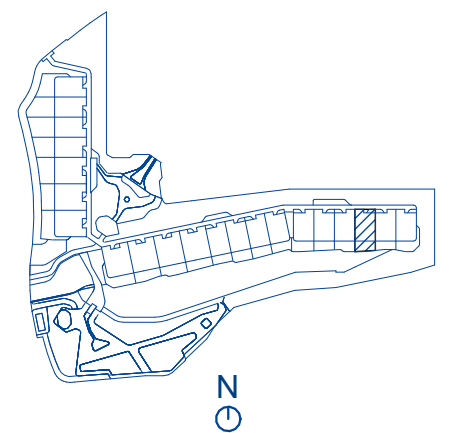
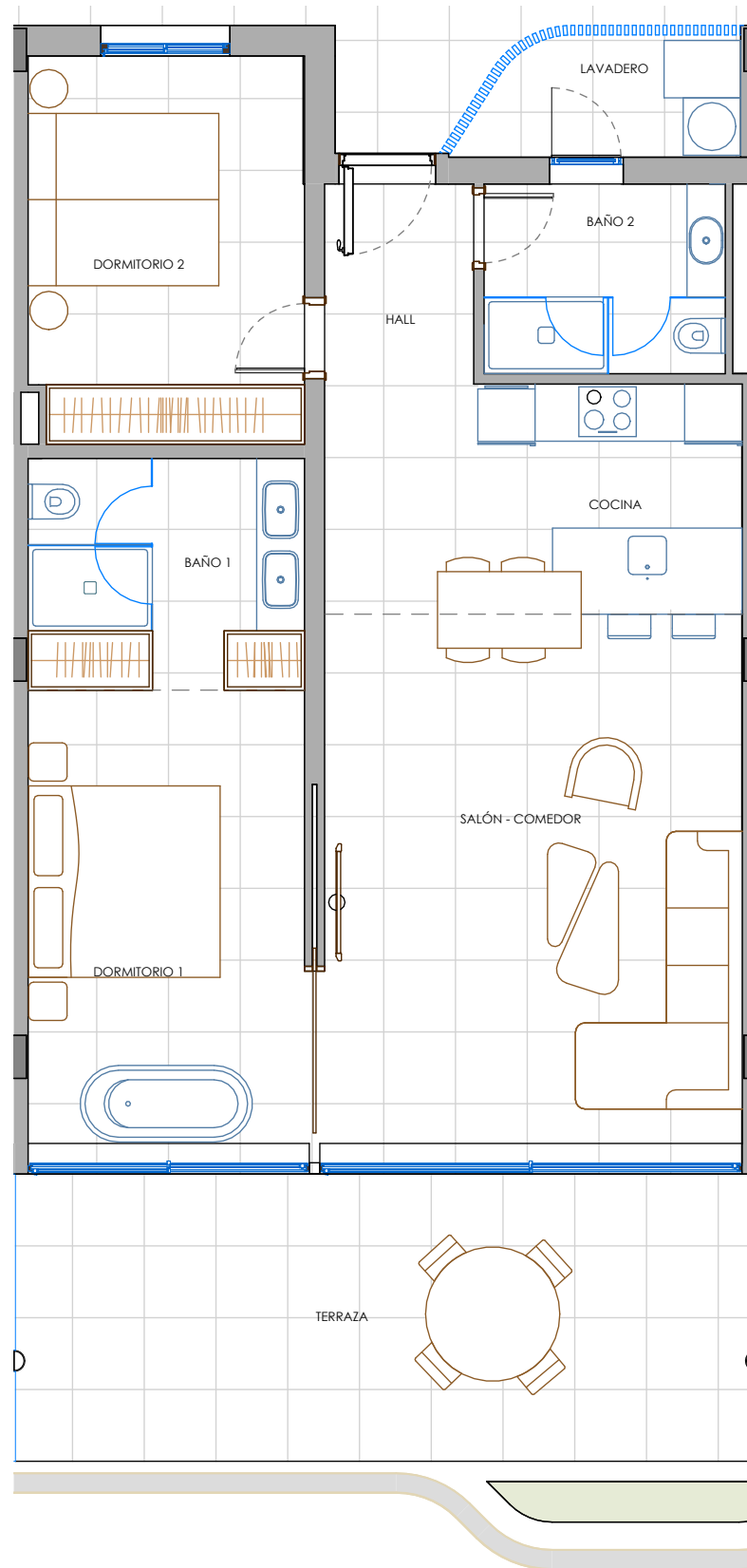

NIÁGARA (Módulo D2)  
P2 L  
Apartamento nº 221

SUPERFICIE CONSTRUIDA VIVIENDA..... 90.87 m<sup>2</sup>  
SUPERFICIE CONSTRUIDA TERRAZA..... 25.36 m<sup>2</sup>

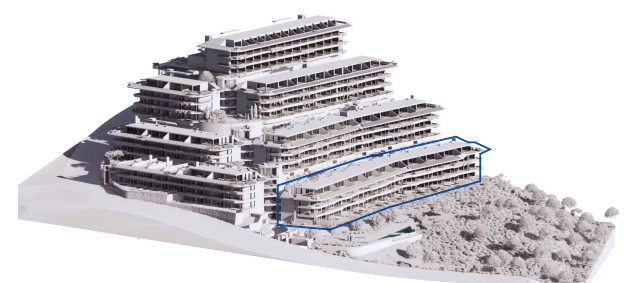
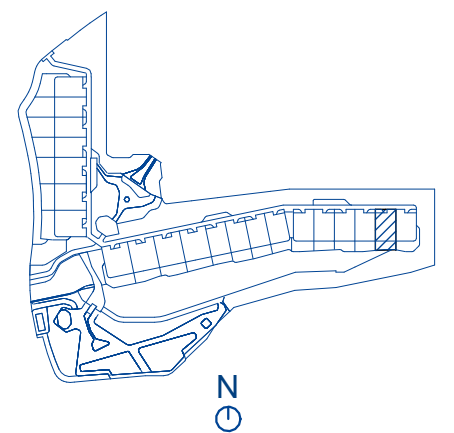
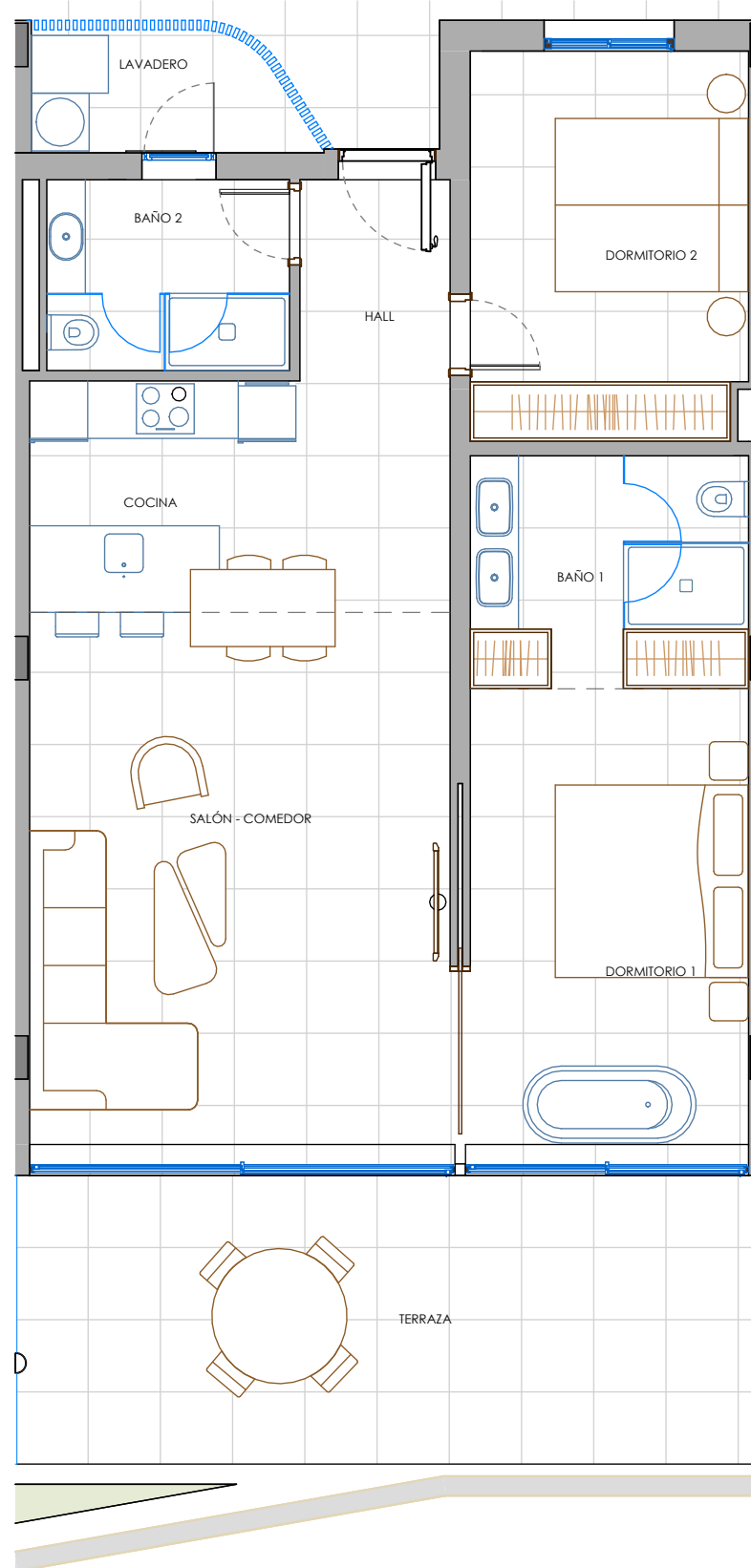

NIÁGARA (Módulo D2)  
P2 M  
Apartamento nº 222

SUPERFICIE CONSTRUIDA VIVIENDA..... 90.94 m<sup>2</sup>  
SUPERFICIE CONSTRUIDA TERRAZA..... 25.27 m<sup>2</sup>

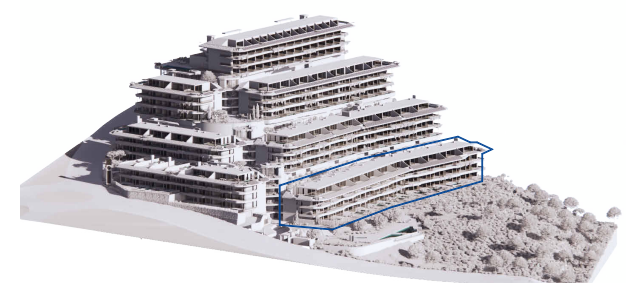
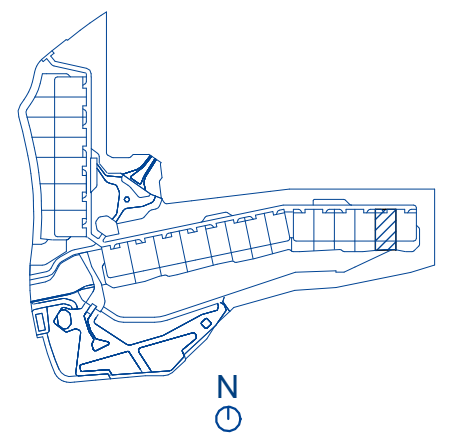
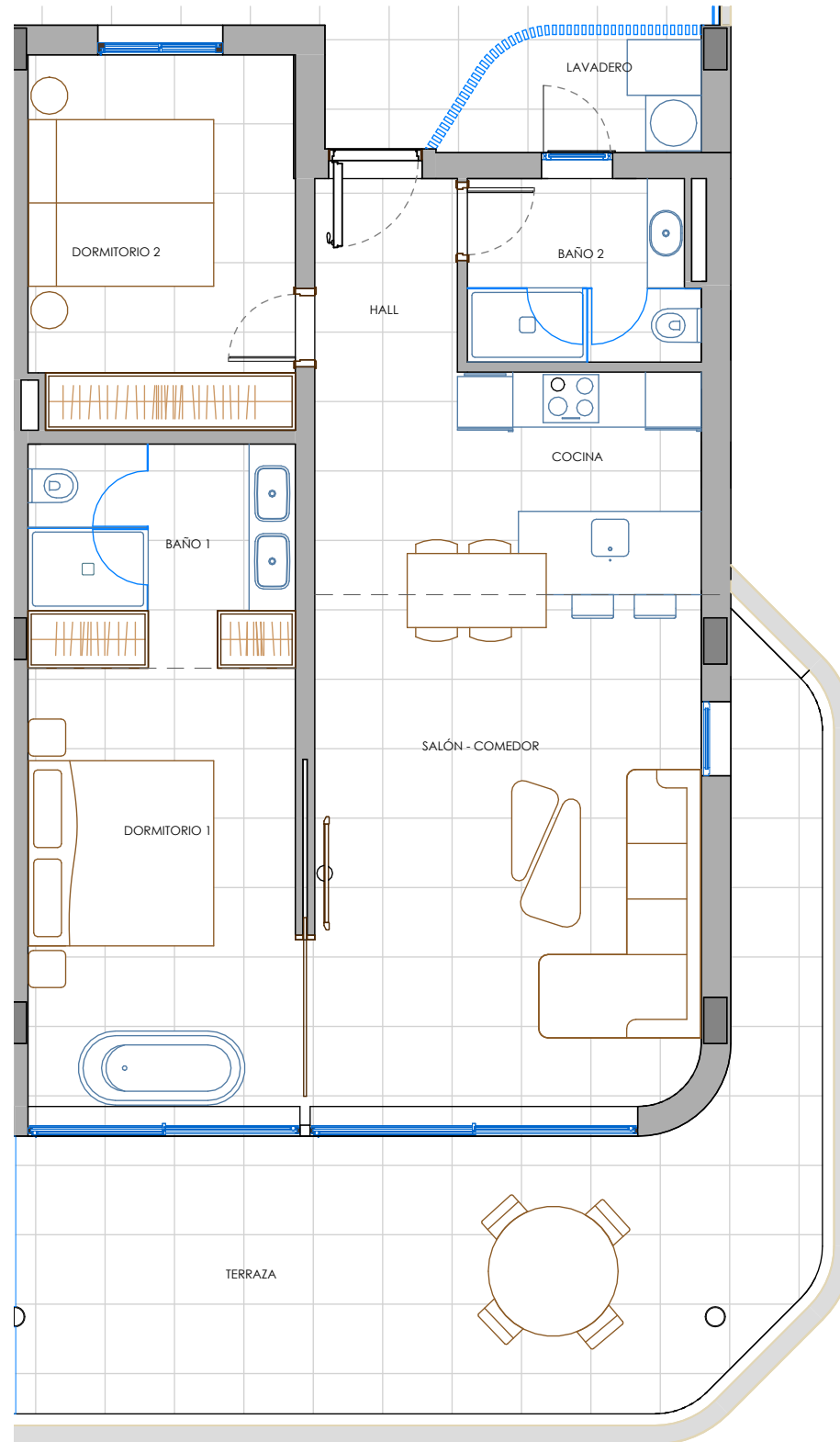

NIÁGARA (Módulo D2)  
P2 N  
Apartamento nº 223

SUPERFICIE CONSTRUIDA VIVIENDA..... 90.59 m<sup>2</sup>  
SUPERFICIE CONSTRUIDA TERRAZA..... 36.16 m<sup>2</sup>

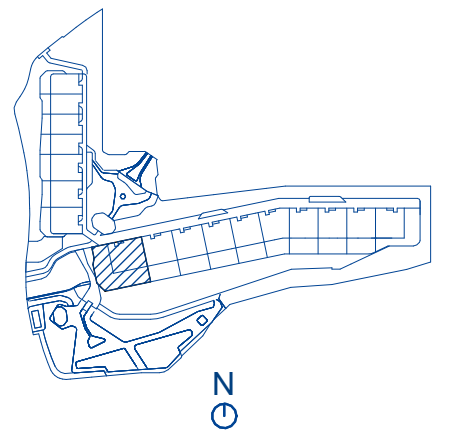
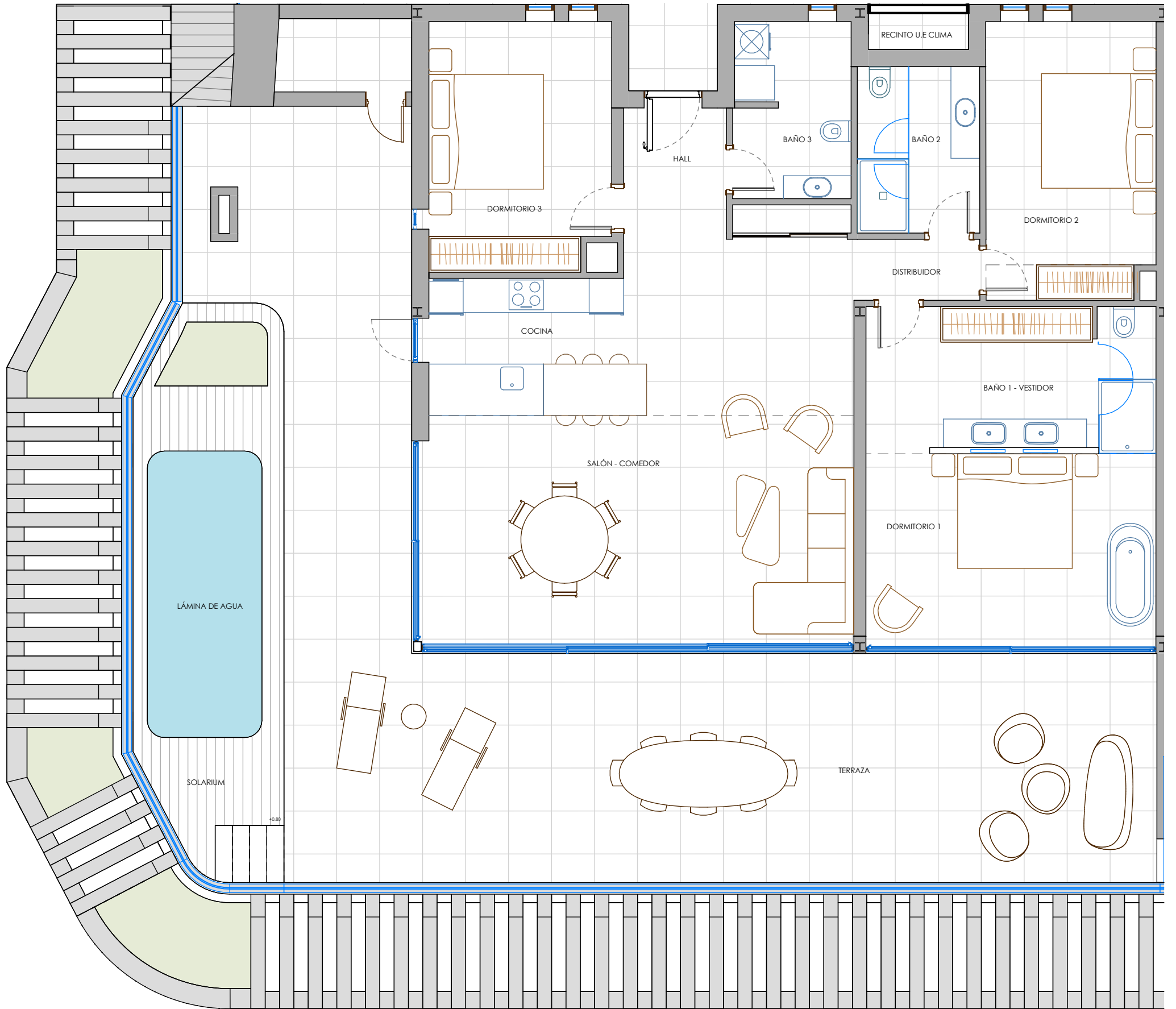

NIÁGARA (Módulo D2)  
Ático A  
Apartamento nº 224

SUPERFICIE CONSTRUIDA VIVIENDA.....	150.11 m <sup>2</sup>
SUPERFICIE CONSTRUIDA TERRAZA.....	96.26 m <sup>2</sup>
SUPERFICIE LÁMINA DE AGUA & SOLARIUM.....	23.27 m <sup>2</sup>
<b>SUPERFICIE EXTERIOR TOTAL</b>	<b>119.53 m<sup>2</sup></b>

